

IMPORTANT! KEEP THIS MANUAL FOR FUTURE REFERENCE

INSTRUCTION MANUAL FOR DIGITAL AUDIO BABY MONITOR ASTRO

ASTRO

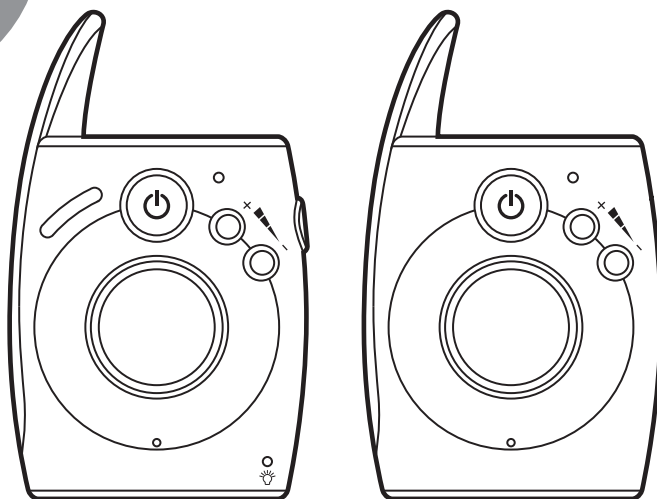

This **chipolino** product is manufactured in accordance with the requirements of Directives of the European Parliament and Council 2014/53/EU relating to the making available on the market of radio equipment, Directive 2011/65/EU on the restriction of the use of certain hazardous substances in electrical and electronic equipment (RoHS), Directive 2009/125/EC, establishing a framework for the setting of ecodesign requirements for energy-related products, Regulation (EC) No 1907/2006 concerning the Registration, Evaluation, Authorisation and Restriction of Chemicals (REACH) and 2001/95/EU on General Product Safety as well as in accordance with National Legislation. The conformity of this certified with test reports, mentioned in the declaration of compliance of this products, which can be found at www.chipolino.com.

TO GUARANTEE THE SAFE USE OF THIS PRODUCT, FOLLOW THE WARNINGS, GUIDELINES AND RECOMMENDATIONS IN THIS MANUAL!

ATTENTION! WARNINGS!

- **CAUTION!** THIS PRODUCT IS INTENDED TO AID YOU AND CANNOT SUBSTITUTE A REAL AND RESPONSIBLE ADULT SUPERVISION!
- **CAUTION!** USE THE PRODUCT ONLY FOR ITS PURPOSE!**CAUTION!**
- **CAUTION!** ONLY AN ADULT SHOULD USE THE PRODUCT!
- **CAUTION!** THIS DEVICE IS NOT A TOY AND MUST NOT BE ACCESSIBLE TO CHILDREN! Do not let children play with parts of the monitor!
- **CAUTION!** NEVER PLACE THE BABY UNIT IN THE BABY'S BED OR PLAYPEN! Place the transmitter no less than 2 m away!
- **CAUTION!** THE ADAPTORS, PARENT AND BABY UNITS MUST ALWAYS BE OUT OF THE REACH OF THE BABY TO AVOID RISK OF INJURY OR SUFFOCATION!
- **CAUTION!** BEFORE USE, INSPECT THE GOOD WORKING ORDER OF ALL PARTS OF THE PRODUCT. Do not use the product if you find some parts are missing or damaged.
- **CAUTION!** NEVER USE THE BABY MONITOR IN MOIST ENVIRONMENT, CLOSE TO OR IMMERSSED IN WATER!
- **CAUTION!** KEEP AWAY FROM FIRE. To avoid overheating keep the transmitter, receiver and adaptors away from heat sources or other devices, which release heat.
- **CAUTION!** Do not leave the adaptors in a place where a child may step on them. A hit on the adaptor when plugged in the electricity may cause damage and serious risk of injury!
- If you use a wireless telephone, wireless video device, Wi-Fi network, microwave or Bluetooth devices at frequency of 2.4 GHz, and the video monitor units show interferences, relocate the baby unit at a larger distance until the interference disappears.
- Do not use spare parts or other components, which are not supplied by the manufacturer! The producer does not assume responsibility in case spare parts have been used which are different from the approved type or recommended by the producer.
- Do not make changes or modifications on the product! Do not modify the electric circuit and do not add other electrical parts! If necessary, contact the retailer or an authorized service center for advice and repair.
- Before plugging the adaptors in, check if the voltage marked on the adaptor is the same as the voltage of the local electricity network. If not, you will damage the product!
- Do not use damaged adaptors.
- Do not remove the labels and warnings on the product! They are important for everyone who uses the product!
- Keep the nylon package away from children to avoid suffocation!

WARNINGS FOR USING BATTERIES

- Always secure the batteries compartment with the cover after you installed the batteries.
- Do not allow children to have access to the batteries or play with them!
- Install batteries only with the needed size and voltage.
- Do not use batteries with different size.
- Do not mix new and used batteries.
- Obey the given polarity at batteries compartment.
- Remove damaged or dead batteries.
- Remove the batteries when you are not going to use the product for a long period of time.
- Remove the batteries from the product while you are using the adaptors.

- Do not throw the batteries in open fire. Do not disassemble the batteries.
- **CAUTION!** When you stop using the product, do not dispose of it with normal household waste but hand it over in an official waste collecting point. The waste formed from damaged electrical and video devices, batteries, adaptors, must be disposed of separately. Throwing them out in containers for household waste is forbidden.



PRODUCT FEATURES

Frequency	2,4 GHz
Modulation (32 channels)	FHSS
Suitable ambient temperature	От 0°C до +50° C
Suitable ambient moisture	20%-80% RH
Suitable storage temperature	25° C
Transmission power	17dBm
Range (without obstacles)	Up to 300 m in open area
Adaptor, 2 pcs	In: 100-240V, 50-60Hz, 0,3A Out: DC5V 1000mA
Two way communication	YES
VOX (the baby unit is automatically on when sound is detected)	YES
Parent unit: RECEIVER, 1 piece	
Power consumption	min: 50mA max: 240mA
Audio Out	300mW
Receiving sensitivity	-88dBm
Battery, size AAA (not included)	3x1.5V
Belt clip	YES
Baby unit: TRANSMITTER, 1 piece	
Power consumption	min: 25mA max: 125mA
Battery, size AAA (not included)	3x1.5V
Position of the transmitter to child	1,5-2 m

INSTRUCTIONS FOR USAGE. FUNCTIONS

CAUTION! TO BE USED ONLY BY AN ADULT!

TRANSMITTER (BABY UNIT)



VIEW FROM TOP

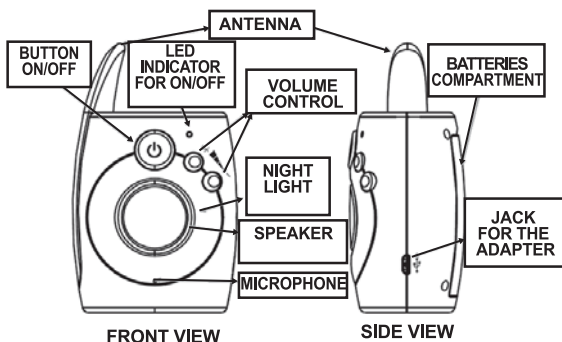

FRONT VIEW

SIDE VIEW

- Install the batteries or plus the adaptors
- Place the units on stable, flat and horizontal surface
- Press the **ON/OFF** button on both units and the LED indicators must light in **green**
- Use the buttons for **volume control** to adjust the sound level
- Press **two way communication ON/OFF button** to be able to speak to your child through the speak on baby unit

RECEIVER (PARENT UNIT)



VIEW FROM TOP

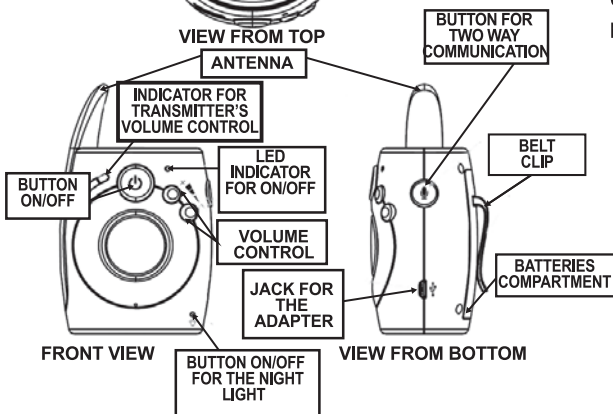

FRONT VIEW

VIEW FROM BOTTOM

- Pressing the **night light ON/OFF button** no matter which unit, the **night light** on the baby unit turns ON and the LED indicator on parent unit activates.

ADVICES FOR BETTER RANGE AND OPERATION

- For better operation and during longer period of usage, we recommend you to use adaptors, not batteries to supply both units.
- When the batteries are low, the LED indicator will light in orange/red.

- When the transmitter and receiver are located in long distance between each other, this could affect the connection quality and the receiver may not get signal from the transmitter. Then you will hear an alert to show you that units are out of range and indicators for ON/OFF will blink. It is recommended to cut the distance between both units.
- When the transmitter and receiver are located too close to each other, you will hear an acoustic sound. Distance both units or reduce the sound level of the receiver.
- If between both units there are many walls or sailings or you use wireless phone, wireless video, Wi-Fi net, micro oven or Bluetooth devices on frequency 2.4 GHz, the transmitter or receiver may get disorder. Place the parent unit somewhere else closer to baby unit or turn off other wireless devices.

INSTALLATION OF THE BATTERIES IN BOTH UNITS

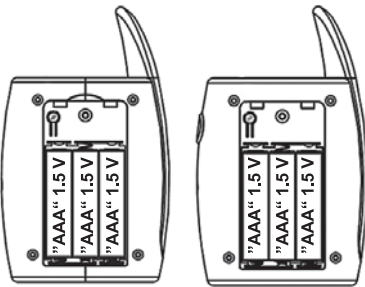

**BABY
UNIT**

**PARENT
UNIT**

Tools you need: a screwdriver.

- Remove the covers of the batteries compartment
- Install in each unit 3 pcs size AAA/ 1.5V batteries obeying the given polarity
- Secure the batteries with the cover

IMPORTANT! Remove the batteries while you are using the adaptors to supply both units.

PAIRING THE UNITS

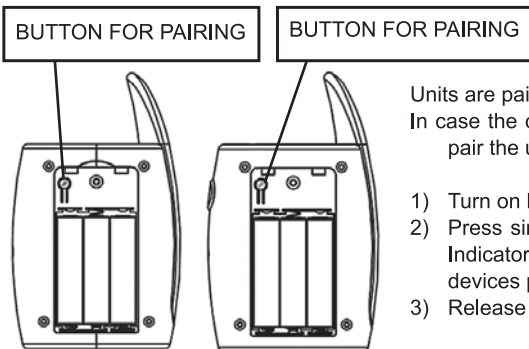

**BABY
UNIT**

**PARENT
UNIT**

Units are paired in advance by the producer. In case the connection between the units breaks down, pair the units as described below:

- 1) Turn on both units (ON/OFF button).
- 2) Press simultaneously pairing buttons on both units. Indicators ON/OFF will start blinking until both devices pair successfully.
- 3) Release the buttons.

TROUBLESHOOTING

PROBLEM	SOLUTION
Noise from receiver, when using batteries	Check the power indicator. If light is orange, batteries are exhausted. Insert new batteries.
Signal from transmitter stops suddenly	If the transmitter in baby's room doesn't detect noise from baby or other objects (radio, clock or TV) in the room, it stops transmitting signal to receiver. VOX function is activated. If any sound occurs in baby's room, receiver turns on automatically.
Weak signal	Make sure both devices are in operation range. If necessary, pair both units

CARE AND MAINTENANCE

- Do not step on the power supply cable and keep it from twisting especially around the connectors, socket and the point where the cable comes out of the unit.
- Keep the units for the parent and baby and the adaptors so that they will have sufficient ventilation. Do not cover them with clothes, towels, covers, etc.
- Always unplug the units from the sockets whenever there is thunder or if you will not use them for a long time.
- Do not immerse the parent or baby units in water, do not wash them with running water.
- Clean the parts of the baby monitor and adaptors with a dry towel after you have turned the units off and unplugged the adaptors from the electricity network.
- Store in a dry and cool place.

Materials used: plastic, metal.



1 Golyamokonarsko shosse, Plovdiv, BULGARIA
www.chipolino.com