

EN

# **ASSEMBLY AND OPERATION MANUAL**

***Pressurized water flow heater  
PERFECT 7000, 8000, 9000***

## Advantages of pressurized water flow heaters “PERFECT”:

- Significant electric power saving comparing to a boiler
- Instant and permanent warm water delivery
- Electronic power switch prolongs significantly heater’s life
- Possibility to use the heater with very low water pressure (ca 0,06 MPa)
- Thanks to installed electronic control system the most unreliable mechanical parts such as membrane, traditional electrical contacts are eliminated. Significant prolongation of the appliance life and improved reliability is reached in result.

## 1. Application

---

Pressurized water flow heater PERFECT is designed for instant delivery of warm water to sanitary equipment such as wash basins, sinks. In order to economical use the heater should be installed as close as possible to the served equipment.

This appliance is fully designed to be used in moisture environment. However splashing with water is prohibited. Maximum delivered water temperature should not exceed 30°C.

One should remember that heater output depends on:

- it electric power;
- water stream flowing through the appliance. The bigger flow, the lower water temperature on exit (table 1);
- voltage drop in electrical system. For instance: voltage drop by 10% results in lowering heat output by 19% (table 2). Voltage drop below 340 V causes blockage of appliance power switch by electronic system;
- delivered water temperature.

Supplied water temperature 15°C

Water flow	[l/min]	<b>2,5</b>	<b>3</b>	<b>3,5</b>	<b>4</b>	<b>4,5</b>
<b>Perfect 7000</b>	[°C]	55	48	43	40	37
<b>Perfect 8000</b>	[°C]	60	53	47	43	40
<b>Perfect 9000</b>	[°C]	–	57	51	46	43

Table 1

Heater power depending on voltage in electric system

Voltage	[V]	400	390	380	370	360
<b>Perfect 7000</b>	[W]	7000	6650	6300	5989	5670
<b>Perfect 8000</b>	[W]	8000	7600	7200	6800	6480
<b>Perfect 9000</b>	[W]	9000	8550	8100	7650	7290

Table 2

### CAUTION!

**Power must be switched off before starting any work over installation, opening cover or incline the installed heater!**

**The heater can only work in position showed on drawing No 1 below. Starting the device in position other than proper one will result in damaging a heating element and deprivation of guarantee.**

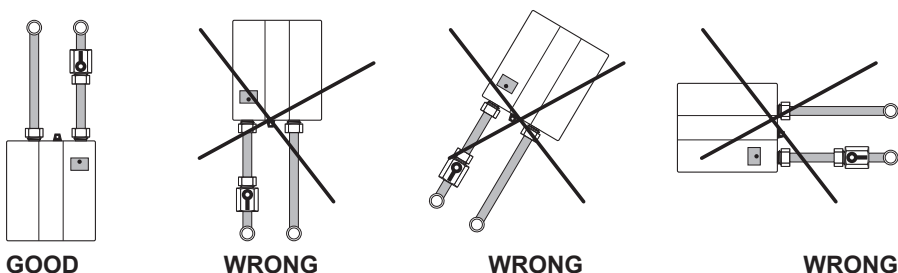

Fig. 1

## 2. Safety regulations

- Heater can only be installed by authorized person
- Heater must permanently be connected to electrical system equipped with earthing connector and differential switch
- Heater can only work in position presented on drawing 1
- Do not exchange earthing wire with live wire
- Heater can only work using perfectly working safety devices
- Heater must not be installed in rooms where temperature drops below 0°C
- If there is a non-return valve installed on the water supply pipe the safety valve must be fitted between unit and non-return valve.
- The unit must never be exposed to temperatures below 0°C.
- The unit can only be connected to the cold water supplies.
- Electric installation must be equipped with residual current protective devices and other solutions which will ensure disconnecting the heater from the source of power (intervals between all their poles should not be less than 3 mm).
- Appliance should not be installed in aggressive or danger of explosion environment

- Heater can only be used when in perfect technical condition
- Water and power supply must immediately be shut off in case of heater's failure
- All service and maintenance works can only be completed with power switched off
- Only original spare parts can be used for repair
- Heater's cover must not be taken away while power is on
- Avoid electronic system to be splashed with water
- In case of heater's defect or improper work switch off power and shut off water supply using stopping – suppressing valve
- Sprinkler (strainer) on water tap drain tube end should be cleaned regularly
- Check regularly power supply system (voltage drop) including connection to the main
- Water flow should be suppressed in such manner as to fill comfortable water temperature (water should not to be too hot – beware children!)
- Do not allow children use or play with heater independently
- This device may be used by children over three years old and people with limited physical, sensory or mental abilities, or with no experience and knowledge if they are supervised or were provided with instructions regarding the use of the device in a safe way and understand possible dangers.

### 3. Wiring system

---

- The heater can only be used previously connected to earthing system.
- Wiring system should be equipped with differential switch.
- Minimum wire cross section and fuse value should be found according to table 3.
- Check state of wiring system and particularly terminals before heater installation.
- Measure voltage drop under load after connecting heater to wiring system.

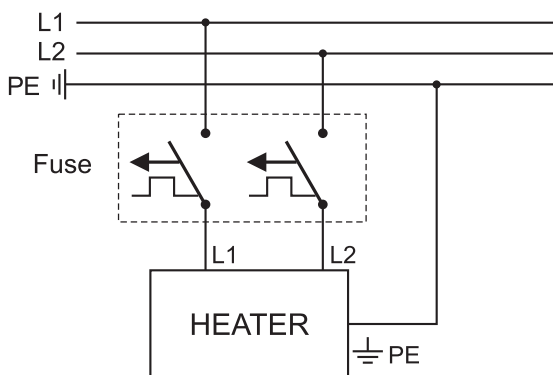

Fig. 2

Typ	Perfect 7000	Perfect 8000	Perfect 9000
Minimum wire cross section [mm <sup>2</sup> ]	2,5	2,5	2,5
Recommended fuse [A]	17,5	20	22,5

Table 3

## 4. Water system

---

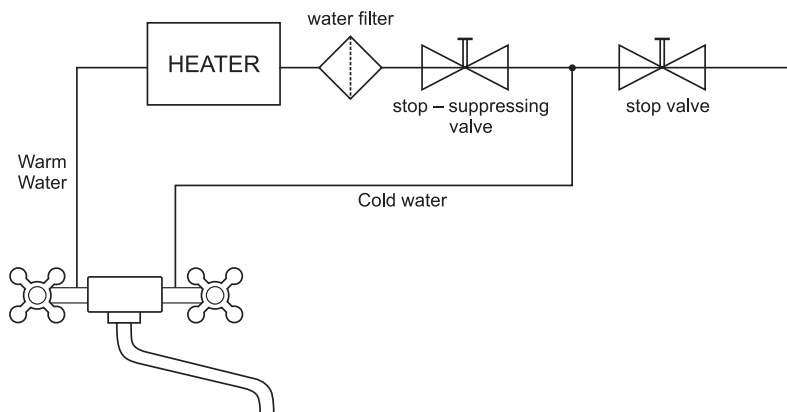

## 5. Assembly

---

### CAUTION!

The device can only work in position showed on drawing No 1.

Trying to start the device in position other than proper one or without water filter will result in damaging heating element and deprivation of guarantee.

Do not screw connecting hoses using high power in order to avoid thread damage.

Do not seal stub pipe thread with tow or Teflon™ sealing tape.

Save electronic system against water splashing.

1. Apply pattern on place the heater will be installed. Mark places for drilling holes for anchoring pegs and cable.  
Cable can be connected to the heater by opening in rear wall or by braking thin plastic part under housing (fig. 3 and 4).

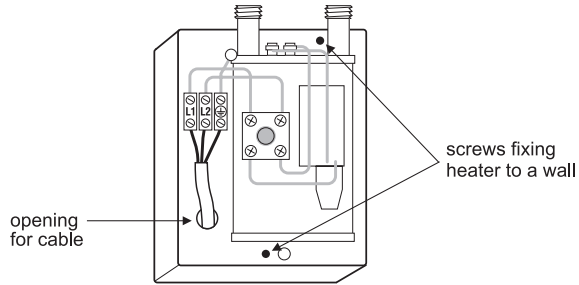

Fig. 3

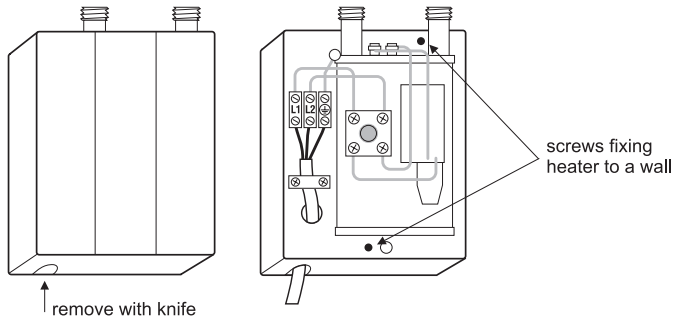

Fig. 4

2. Screw heater on a wall.
3. Connect heater in a way showed on fig. 6. Remember to fit water filter as showed on fig. 5. Use flexible hoses designed for pressurized system with rubber gasket. Do not exchange heater outlet (red colour) with intake (blue colour).

**CAUTION! Do not screw hose nuts too tight in order to avoid thread damage at heater's pipes ends. Water filter removal results in guarantee deprivation. Filter must be installed according to figure 5.**

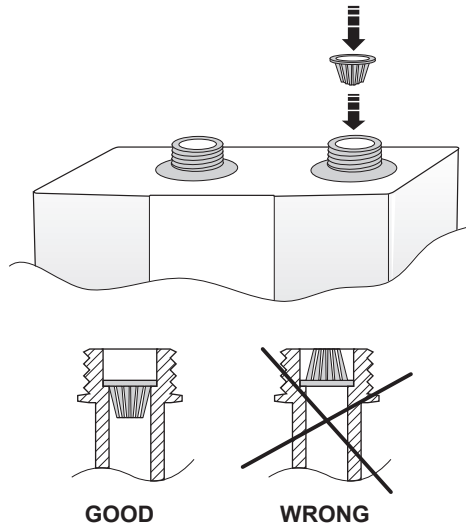
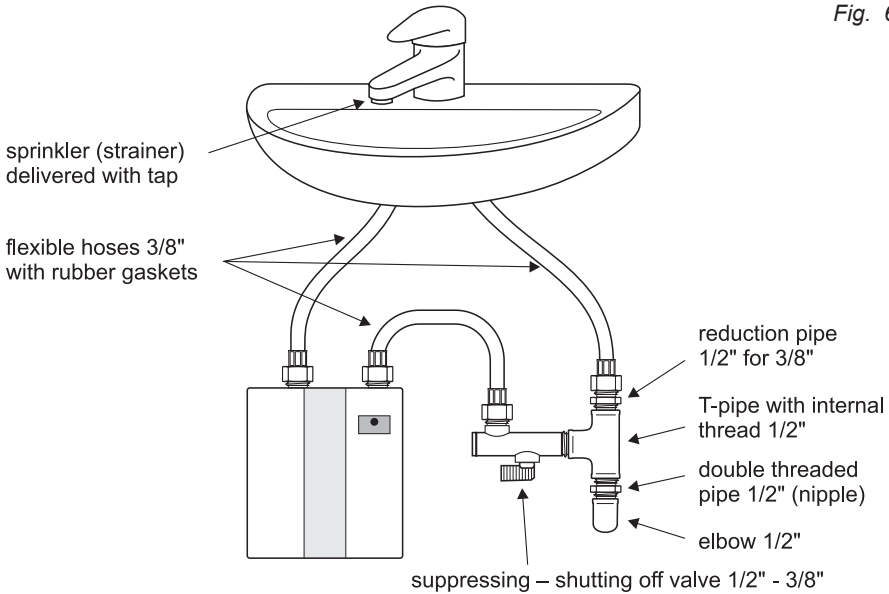

Fig. 5

Fig. 6



*Heater connection to tap assembly with hoses 3/8"*

4. Open water valve and check connections tightness. In case electronic system is splashed with water remove it immediately blowing with compressed air.
5. Open full water flow in order to remove air plug from heating element.
6. Connect heater to the mains supply.

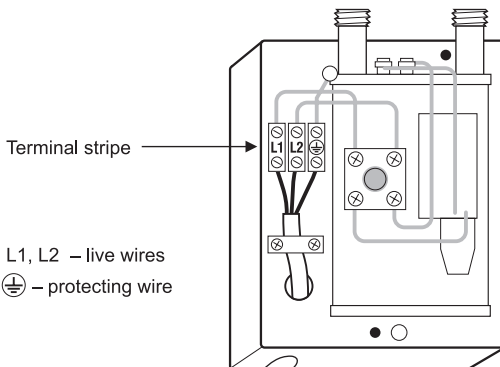

Fig. 7

### **Caution!**

**Please check whether blue and red gaskets of pipes ends are properly fit to the heater's casing after fixing it on heater.**

7. Change water strainer for the one delivered with heater
8. Adjust heater according to chapter 6 .
9. Remember to clean strainer periodically.

## **6. Adjustment**

---

### **Caution!**

**Water temperature delivered by heater depends on water flow. The higher flow, the lower temperature.**

**Too high water temperature can cause thermal protection device to stop heater work.**

**Unlock by pressing thermal protection button.**

1. Open warm water tap.
2. Reduce water flow with care using suppressing – shutting off valve in order to reach water temperature ca 42°C.

## **7. Water filter cleaning**

---

1. Turn off water inflow to suppressing – shutting off valve and disconnect from power supply.
2. Disconnect flexible hose from heater intake.
3. Take out filter (using small screw driver) – see fig. 8.

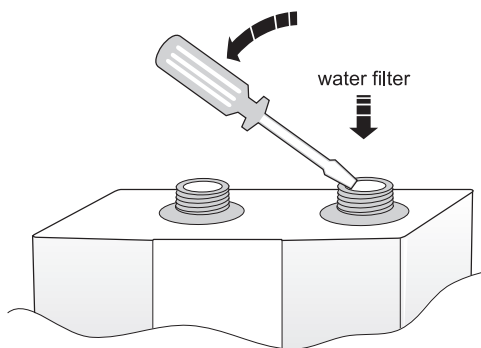

*Fig. 8*



4. Remove dirt from filter.
5. Install filter into heater intake with basket bottom down (Fig. 9)

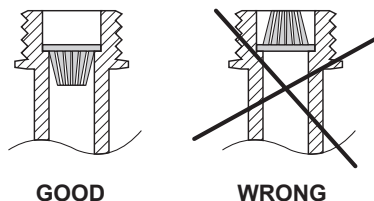

Fig. 9

6. Connect flexible hose to the heater.
7. Open water valve and check tightness.
8. Check electronic system whether is not splashed with water before power switching on – if so, blow it up with compressed air to remove water from electronic circuit board.
9. Adjust according to chapter 6.

## 8. Cleaning sprinkler (strainer) of drain tube

---

1. Unscrew sprinkler from drain tube.
2. Unscrew bolt from sprinkler.
3. Push out rings from sprinkler.
4. Clean up rings ducts.
5. Reinstall sprinkler

## 9. Defects and troubleshooting

---

### Water flow too low

- blocked water filter (clean it out according to chapter 7)

### Heater does not start

- heater inlet exchanged with outlet
- water flow suppressed too much
- blocked water filter (clean it out according to chapter 7).
- water pressure too low
- lack of power because of blown fuse.

### Heater does not warm up water but control lamp lights

- voltage too low (power supplying installation overloaded)
- temperature of entering water too low
- water flow too high (adjust water flow according to chapter 6)

### Water temperature on heater exit to low

- water flow too high (adjust water flow according to chapter 6)
- temperature of entering water too low
- high voltage drop (see chapter 1, table 3)

**Water temperature on heater exit too high**

- water flow suppressed too much by control valve (adjust water flow according to chapter 6)
- blocked water filter (clean it out according to chapter 7)
- water pressure in water system too low

**Heater is switching on and out automatically**

- water pressure oscillation in water system
- water flow suppressed too much by shut off - suppressing valve

**Stepwise changes of water temperature on exit**

- current oscillation in power supply system
- changes of water flow in result of pressure changes in water system

## 10. Technical data

---

Typ	Perfect 7000	Perfect 8000	Perfect 9000
Power [kW]	7	8	9
Current intensity [A]	17,5	20	22,5
Voltage [V]	400	400	400
Minimum water flow to switch heater on [l/min]	2,1	2,4	2,8
Maximum water pressure [MPa]	0,65	0,65	0,65
Splash proofing class	IP24	IP24	IP24
Minimum water resistivity at 15°C	1300	1300	1300

## 11. Outfit

---

1. Heater 1 pc
2. Shutting off – suppressing ball valve 1/2" – 3/8" 1 pc
3. Water filter 1 pc
4. Self – blocking peg Ø6 2 pcs
5. Pattern to drill holes 1 pc
6. Sprinkler (strainer) 1 pc





TOP



Ø6mm

Pattern

DOWN

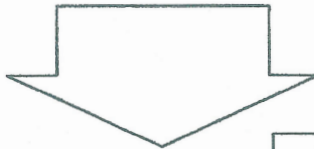

Ø6mm





## **IMPORTANT INSTRUCTIONS CONCERNING THE DETERIORATED DEVICE**

Pursuant to the provisions of the Act dated 29 July 2005 on waste electric and electronic equipment, it is forbidden to put together with municipal waste the deteriorated equipment marked with the symbol of the crossed out bin.

A user who intends to get rid of the product, should take the waste electric or electronic equipment to the point collecting the waste equipment. Collection points are run, among others, by wholesalers or retailers of such equipment as well as by gmina organizational units conducting the activity in the scope of collecting waste.

The above statutory obligations have been introduced in order to limit the amount of waste created from deteriorated electric and electronic equipment, as well as to ensure the proper level of collecting, recovering and recycling the waste equipment. In the equipment there are no dangerous elements which have a particularly negative effect on health and the environment.

The materials used in the device are re-usable. Thanks to re-use, re-use of materials, or other forms of use of the deteriorated devices, you contribute significantly to the protection of our environment.

