



EN ■ Deep fryer

Translation of the original manual

READ CAREFULLY AND STORE FOR FUTURE USE.**General warnings**

- This appliance must not be used by children 0 to 8 years of age. This appliance may be used by children 8 years old and older when under continuous supervision. This appliance may be used by persons with physical, sensory or mental impairments or by persons with insufficient experience and knowledge, if they are properly supervised or have been informed about how to use the appliance in a safe manner and understand the potential dangers.
- Children must not play with the appliance.
- Cleaning and maintenance performed by the user must not be performed by unsupervised children.
- Keep the appliance and its power cord out of reach of children younger than 8 years of age.
- In the event that the power cord is damaged, have it repaired at a professional service centre to prevent causing a dangerous situation. It is forbidden to use the appliance if it has a damaged power cord.
- The surfaces of the appliance that come into contact with food must always be cleaned according to the instructions in this user's manual.
- This appliance is not designed to be controlled using a programmed device, external timer switch or remote control.
- This appliance is designed for domestic use and similar locations such as:
 - kitchens in stores; offices and other workplaces;
 - in agriculture;

- for guests of hotels, motels and other similar locations;
- in bed and breakfast establishments;



Attention:
Hot surface.

- The appliance must be located in a stable position with the handles positioned in such a way as to prevent spilling hot liquids.
- The outer body of the appliance, the frying pot, the frying basket and the inside parts of the lid become very hot during use!

Electrical safety

- Before connecting this appliance to a power socket, make sure that the voltage stated on its rating label corresponds to the voltage in your power socket.
- Connect the appliance only to a properly grounded socket. Do not use an extension cord.
- Do not connect and disconnect the power cord to and from the power socket with wet hands.
- Ensure that the power plug contacts do not come into contact with water or moisture.
- Do not disconnect the appliance from the power socket by pulling on the power cord. This could damage the power cord or the power socket. Disconnect the cord from the power socket by gently pulling the plug of the power cord.
- Do not place heavy items on the power cord. Make sure the power cord does not hang over the edge of a table and that it is not touching a hot surface or sharp objects.
- To avoid the danger of injury by electrical shock, do not repair the appliance yourself or make any adjustments to it. Have all repairs or adjustments of the appliance performed at an authorised service centre. Tampering with the appliance during the warranty period may void the warranty.
- To prevent the risk of injury by electrical shock, never submerge the slow cooker unit, the power cord or the power plug in water or any other liquid.
- Always turn off the appliance and disconnect it from the power socket when you have finished using it.

Correct use of the appliance

- This appliance is used for frying food. It is not intended for bringing liquids to a boil. Do not use it for any other purpose than for which it was designed.
- This appliance is designed for use in indoor areas only. Never use it in an outdoor or industrial environment.
- This appliance must be used only in accordance with the instructions contained in this user's manual.
- Only use the appliance with the original accessories that came with it.



Attention:
Using non-original accessories may result in a dangerous situation arising.

- Do not use the appliance for indoor heating purposes!
- Always turn off and disconnect the appliance from the mains power socket when not using it, when leaving it without supervision, before cleaning, maintenance or moving it. Never move the appliance during operation.
- Do not use the appliance when it is not functioning correctly or after it has fallen on the floor, been submerged in water or is damaged in any other way. Hand it over to an authorised service centre for inspection or repair.
- Do not turn on the appliance without the frying pot being filled with the frying medium.
- Do not place any items into the frying pot except for the frying basket.
- It is forbidden to modify the surface of the appliance in any way, e.g. using self-adhesive wallpaper, foil, etc.

Installation location of the appliance

- Only use the appliance on an even, dry, clean, stable surface and heat resistant surface.
- Do not use the appliance near flammable materials such as curtains, kitchen towels, etc.
- Do not place the appliance on the edge of a table, on a drainboard, on unstable, inclining or uneven surfaces, on an electric or gas stove and other sources of heat, or in their vicinity.
- To ensure sufficient air circulation during operation, there must be a clearance of at least 15 cm on all sides of the appliance. Do not place any items on to the appliance and do not cover the ventilation openings.
- Do not place the appliance in the vicinity of items, surfaces or under items that may become damaged, for example walls, kitchen cabinets, cupboards, paintings, curtains. The escaping steam could damage them.

Safety during use

- Prior to pouring the frying medium into the appliance, ensure that all its parts are completely dry. With the same level of care, dry all foods prior to placing them into the deep fryer. Otherwise, the hot frying medium will start splashing.
- Be especially careful when handling frozen foods. Remove all pieces of ice. The more ice that remains on the food, the more the frying medium will splash.
- An old, especially dirty, frying medium may ignite spontaneously when overheated. Replace the frying medium in a timely manner. In the event of a fire, unplug the power plug and smother out the burning frying medium with a blanket.

**Warning:**

Never use water for extinguishing a deep fryer fire.

- Never add more frying medium into the frying pot than up to the MAX mark and never less than to the MIN mark. Whenever turning on the deep fryer, ensure that there is a sufficient amount of frying medium inside.
- Never turn on the appliance when there is no frying medium inside the frying pot. Otherwise, it may overheat.
- Never melt pieces of shortening fat in the deep fryer. If the shortening fat does not cover the hotplate, the resulting high temperature may result in damage to the appliance or a fire! Dissolve the shortening fat in another pot or similar container prior to using it.
- The appliance must not be left without supervision when it is in operation.
- When operating the appliance, the lid must be properly closed. Do not place any items on to the lid (e.g. protective gloves, wiping cloths) that could cover the steam outlet.
- During operation there needs to be sufficient area for air circulation above the appliance and around it. Do not cover the appliance or block its vent.
- Make sure that the steam exhaust outlet does not point towards heat sensitive materials or you or other people. Hot steam may cause serious scalding.
- While deep frying, do not touch places where hot steam is being emitted as this may cause burns or scalding.
- Be careful when opening the lid; ensure that the steam escapes away from your body.
- Do not place your hands into the internal area of the appliance while it is running.
- Avoid contact with hot steam, which is released from the vents while the appliance is running.
- When the appliance is in operation, the temperature of accessible surfaces may be higher. Do not touch the hot surface. Otherwise, this could cause burns. Use the handle to remove and carry the hot frying basket.
- Make sure that no water or any other liquid splashes on the power plug or the power socket, and that the hot steam emitted from the appliance is also kept away. If this, nevertheless, occurs, disengage the circuit breaker of the power socket and then carefully dry the power socket and the power plug before further use.
- Do not place the hot frying basket on heat sensitive surfaces.

Handling the appliance and its parts

- When you have finished using the appliance, always handle it in such a way as not to touch its outer surface or other parts that may still be hot as a result of residual heat.
- Do not touch the hot surfaces of the appliance. After turning off and disconnecting the appliance from the power socket, use the appliance's carry handles to lift and carry it. For reasons of increased safety, we recommend using oven mitts.
- It is necessary to pay exceptional care when moving the frying basket when it is filled with hot food.

Safety during maintenance

- Allow the appliance to always fully cool down before cleaning it.
- Regularly clean the appliance after each use according to the instructions in chapter Maintenance and cleaning. Do not perform any maintenance on the appliance apart from the maintenance procedure described in chapter Maintenance and cleaning.
- The outer body of the appliance is not intended to be washed in a dishwasher.
- Never wash the appliance under running water or submerge it in water or another liquid.

A

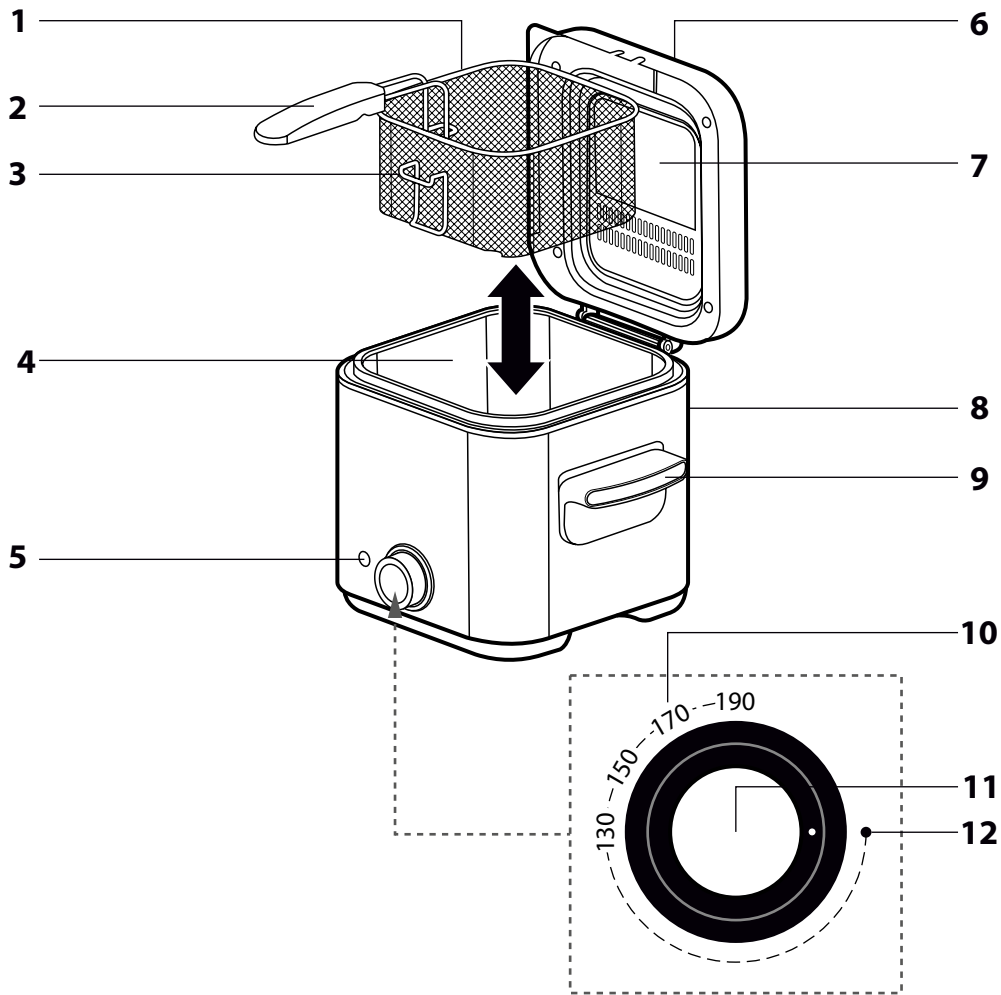

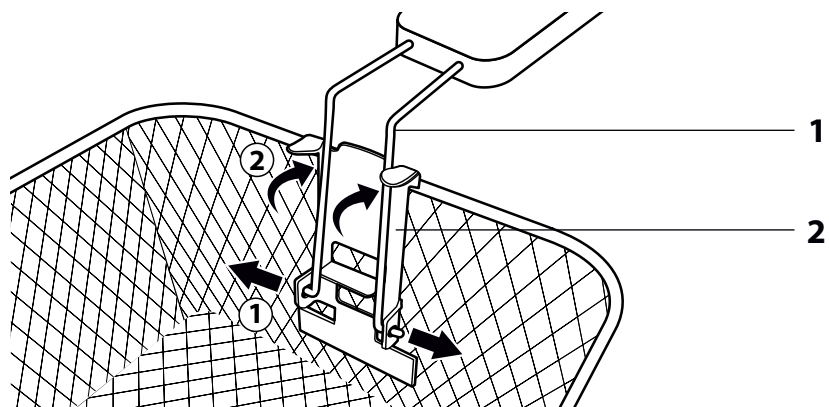
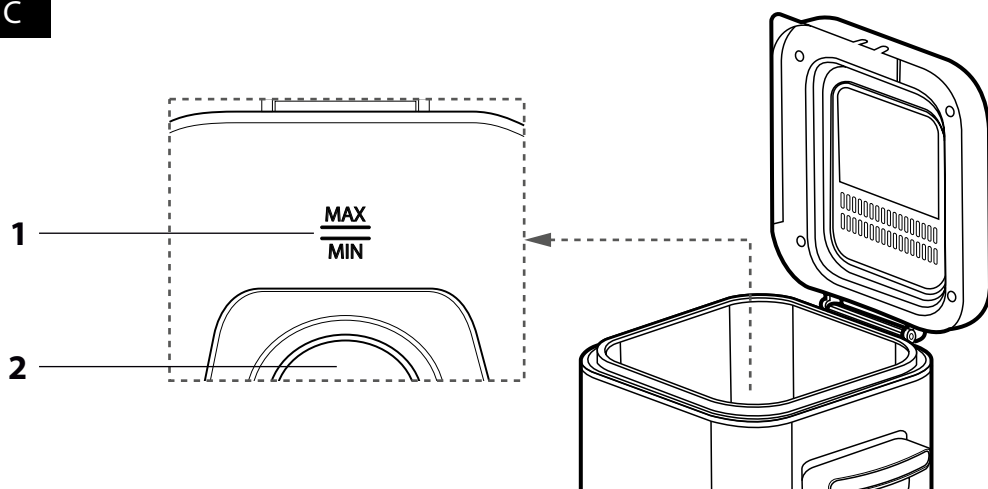
B**C**

D

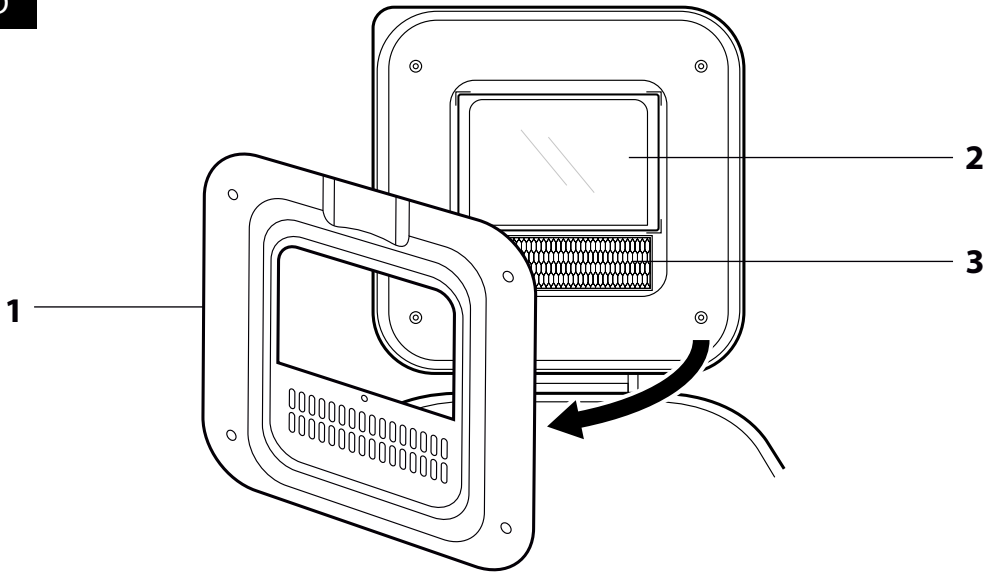

- Prior to using this appliance, please read the user's manual thoroughly, even in cases, when one has already familiarised themselves with previous use of similar types of appliances. Only use the appliance in the manner described in this user's manual. Keep this user's manual in a safe place where it can be easily retrieved for future use. In the event that you hand this appliance over to somebody else, make sure to also include this user's manual.
- Carefully unpack the appliance and take care not to throw away any part of the packaging before you find all its parts. We recommend saving the original cardboard box, packaging material, purchase receipt and responsibility statement of the vendor or warranty card for at least the duration of the legal liability for unsatisfactory performance or quality. In the event of transportation, we recommend that you pack the appliance in the original box from the manufacturer.

DESCRIPTION OF THE APPLIANCE

A1 Frying basket from chrome-plated steel	A9 Deep fryer unit handles They are heat-resistant and prevent any burns and enable the handling of the appliance while it is operation without the need for protective gloves
A2 Removable basket handle	A10 Deep frying temperatures 130 °C, 150 °C, 170 °C and 190 °C
A3 Fixed basket bracket for draining the frying medium	A11 Temperature control knob
A4 Frying pot	A12 "Off" position
A5 Power indicator	
A6 Lid	
A7 Viewing window for inspecting the frying process	
A8 Deep fryer body	
B1 Handle wires	B2 Wire holder
C1 Minimum and maximum frying medium level marks	D1 Lid cover plate
C2 Hotplate	D2 Transparent glass
	D3 Metal filter

INTENDED USE OF THE DEEP FRYER

This deep fryer is intended exclusively for deep frying food using suitable oil or shortening fat. It is not intended for heating water or other liquids or for cooking food directly in the frying pot without the use of a frying medium.

BEFORE FIRST USE

- Before using it for the first time, wash the frying pot **A1** together with the handle **A2** using a hot detergent solution. Then rinse all these parts with clean water and dry them thoroughly with a fine wiping cloth. Both these parts can also be washed in a dishwasher.
- Also clean out the inner and outer parts of the deep fryer unit using a lightly dampened wiping cloth and then wipe it dry. Never submerge the deep fryer unit in water or any other liquid!

OPERATION

PREPARING THE DEEP FRYER FOR FRYING

- Place the deep fryer on a suitable even surface that is out of children's reach. Always position the handles of the deep fryer so that nobody can brush against them and knock or tilt the deep fryer over, or spill its hot contents.
- If you wish to place the deep fryer on a cooktop underneath a range hood, ensure that the cooktop is turned off.
- Take out the frying basket and insert the handle **A2** into the frying basket by squeezing the basket wires **B1** towards each other with your fingers and insert the bent ends into the holes in the bracket **B2** on the basket. Then apply gentle pressure to secure the wires in the bracket. An audible click will be heard.
- Pour the frying medium (deep frying oil, or a liquid or dissolved shortening fat) into the dry and empty frying pot **A4** up to the MAX mark, see fig C. Only use oils and shortening fats that are explicitly marked as "non-frothing" and suitable for deep frying. This information is provided on the packaging or label.



Warning:

Never pour more frying medium into the frying pot than up to the MAX mark and never less than up to the MIN mark.
Never pour any liquid, for example water, into the frying pot.
Never combine various types of shortening fats or oils together. They could overflow out of the deep fryer.

- Clean the top edge of the frying pot and any other parts, which have been soiled while the frying pot was being filled.

FOOD PREPARATION

- As a rule, cut food into equal-sized pieces to ensure that it cooks evenly.
- If the food intended for deep frying is damp, then dry it first. Always season food with spices only after frying and do not apply the spices above the frying pot or during the course of frying.
- If you wish to deep fry coated/battered food, ensure that it is evenly coated/battered and that any excess breadcrumbs are tapped off because loose breadcrumbs spoil the quality of the frying medium.
- Certain types of food, such as doughnuts, can be deep fried directly in the frying pot containing the frying medium without using the frying basket.

- Cut large pieces of food, e.g. chickens, into smaller pieces. This will prevent subsequent scalding when removing the food from the basket.
- Do not place too many food pieces on top of each other, they could stick together.
- Remove any excess ice from frozen foods since it could cause the oil to boil over.
- Do not fill the basket more than halfway, otherwise the temperature of the frying medium will fall and the frying result will not be optimal.

DEEP FRYING

- Connect the power cord plug to a power socket.
- Set the temperature control knob **A11** to the required temperature. Information about the appropriate temperature is found on the food label or in the table in this user's manual. The indicator light **A5** will be lit. The temperature is reached when the indicator turns off and takes approximately 10 minutes.
- Slowly insert the basket with the food into the frying pot. Then tilt down the lid, and deep frying can begin. Steam may escape through the lid during the deep frying process. This is normal and does not constitute a fault.



Attention:

When deep frying food that contains a large amount of water or frozen foods, lower the basket into the frying medium slowly. This will prevent it from overflowing.

- While frying, we recommend to stir the food occasionally to prevent it from sticking together. You can monitor the progress of deep frying through the viewing window in the lid.



Note:

The thermostat will automatically turn on and off to maintain the correct temperature of the frying medium. Based on this, the power indicator light will intermittently turn on and off.



Warning:

The deep fryer and its lid are very hot during the deep frying process. In the event that it is necessary to handle the deep fryer during its operation, always use oven mitts and only handle it using the handles **A9**.

- When you have finished deep frying, turn the control knob to position **A12** (off). Tilt open the lid so that you do not come into contact with hot steam, pull the basket above the level of the frying medium and then hang it on the fixed bracket **A3** in the drip position. Allow excess oil to drip off the food.

Warning:

Never touch the frying basket when you have finished deep frying, it is very hot! Lift the frying basket out of the deep fryer only by the basket handle.



- Allow the deep fryer to cool down with the lid open to prevent water from condensing.
- After the oil drips off, put the deep fried food into a suitable container. We recommend to line the container with a suitable kitchen paper towel.

Recommended time and temperature table

- Generally, it is recommended to use lower temperatures for brittle foods (vegetables, fish) and higher temperatures for frozen foods (French fries, chicken, etc.).



Note:

The frying times and temperatures are only of informative character.

Food	Time (min)	Temperature (°C)
Mushrooms	3	150
Onion rings	3	150
Zucchini	3	150
Fish	3-5	150
Doughnuts	3-5	170
Chicken nuggets	6-8	170
Chicken pieces	13-20	170
French fries (frozen)	6-9	190

Deep frying tips

- When frying lighter foods such as French fries, select a higher temperature. On the other hand when frying bulkier foods such as chicken drumsticks or meat balls, select lower temperatures to ensure the foods are evenly fried inside.
- It is appropriate to fry French fries in two phases. In the first phase, fry them for 5-10 minutes at 170 °C and then allow them to cool down. In the second phase, fry them for 2-4 minutes at 190 °C.
- When frying several food types start with those that require the lower temperature.
- When frying pre-fried foods, use a higher temperature and a shorter frying time than for raw foods.

Removing unpleasant odours from the frying medium

- Some foods, for example fish, may impart an unpleasant odour to the frying medium. This odour can be neutralised using the following method:
 - heat the frying medium to a temperature of 160 °C
 - place a few shoots of parsley or two slices of bread into the frying medium,
 - wait until "bubbles" stop forming, then using a suitable utensil, remove the parsley or bread.

Overheating protection

- The fryer is equipped with a safety fuse against overheating, which protects it against damage. In the event of the fryer heating up excessively, e.g. due to long use or accidentally starting it without the frying medium, the safety fuse against overheating will be activated automatically. In such a case, the deep fryer will shut off. Disconnect the deep fryer from the power socket and allow it to cool down. Contact an authorised service centre to request a replacement of the safety fuse. Under no circumstances should you replace the safety fuse yourself.



Attention:

Despite the fact that the deep fryer has overheating protection, do not use it empty without the frying medium. The incorrect use of the deep fryer may negatively affect its working order and lifetime.

Handling the frying medium

- When not using the deep fryer regularly, it is recommended to pour the cooled down frying medium into enclosed bottles or other deep frying containers and to store it in a refrigerator or another cool place. Pour the frying medium into bottles through a fine strainer to filter out food residues.



Warning:

Prior to transferring the frying medium, always allow it to cool down sufficiently to prevent serious burns.

- It is not necessary to replace the frying medium after every use. If you fry mainly potatoes and filter the frying medium, it is possible to reuse it 8 to 10x. Do not use the same frying medium for more than 6 months.
- Always replace the frying medium when:
 - it has a brown colour or from the very beginning stinks or smokes
 - there is too much water in it. A high water concentration in the oil or shortening/fat is indicated by bubbles and water drops, water steam and a rapidly rising oil or shortening/fat. If the water concentration in the deep fryer is too high, it may happen that the oil or shortening fat may explode out, which can be very dangerous to both the people using the deep fryer as well as those in its vicinity.
- If you wish to replace the frying medium, proceed as follows:
 - prepare a container with an appropriate volume
 - disconnect the deep fryer from the power grid
 - tilt open the lid, take out the frying basket, hold the deep fryer unit by its handles and pour out the frying medium into the prepared container



Warning:

Replace the frying medium only after it has cooled down completely. In the event that shortening fat was used, it must still be partially liquid for it to be poured out.

- Never pour used frying medium into standard household waste. Every municipality has different regulations for the disposal of table oils and fats. Request information about your disposal options at the municipal or town council office.
- If you wish to only filter out the frying medium, proceed as follows:
 - disconnect the deep fryer from the power grid
 - pour the completely cooled down frying medium from the frying pot into another container with a suitable volume capacity.
 - wash the frying pot and dry it thoroughly
 - pour the frying medium back through an appropriate filtration paper

CLEANING AND MAINTENANCE



Attention:

Prior to any cleaning or maintenance, always disconnect the deep fryer from the power grid and allow it to cool down completely.



Attention:

The deep fryer unit and its power cord are not intended for washing in a dishwasher. Do not spray these parts with water or any other liquid or submerge them in water or any other liquid.

- We recommend cleaning the deep fryer immediately after it cools down to prevent food scraps from drying on. These are harder to remove later.
- After every use, wipe the deep fryer unit using a soft damp cloth; wipe the power cord using a dry cloth.
- Slide the handle out of the frying basket and wash both in hot water with detergent, rinse and dry thoroughly with a fine wiping cloth. These parts can also be washed in a dishwasher.

- Wipe out the inside of the deep fryer unit using paper towels, tougher soils can be cleaned using a soft sponge and then wipe it dry.
- In the event that the filter **D3** or the viewing window glass **D2** are very dirty, screw out the cover plate **D1** from the underside of the lid, wash the filter and the glass in hot water with detergent, rinse and dry thoroughly with a fine cloth. Return both parts to their place and screw the cover plate back on.



Attention:

To clean the deep fryer unit or the frying pot, never use chemicals, dishwashing abrasive wool, steel wool or cleaning products with abrasive component since these can damage them.

- Every time the frying medium is poured out, remove any frying medium stains or remains from previous frying that have stuck to the hotplate or the deep fryer unit.

STORAGE

- Before storing it, the deep fryer must be completely cool and disconnected from the power supply, clean and dry.
- Place the frying basket into the frying pot and tilt down the lid.
- Then store the deep fryer in a clean, dry and well-ventilated place out of children's reach.



Attention:

Keep the stored deep fryer away from extreme temperatures, direct sunlight and excessive humidity and do not store it in an overly dusty environment. Do not place any items on the stored deep fryer.

TROUBLESHOOTING

- If the appliance does not work as described in the user's manual, check the list of most frequent problems below in order to remedy the problem. In the event that your problem is not listed or if the problem persists, turn off the appliance, pull the power plug out of the power socket and contact an authorised service centre. Under no circumstances should you attempt to repair the appliance yourself.

Problem	Possible cause	Solution
The fryer is not working	The fryer is not connected to a power socket.	Check that the power plug is connected to a power socket.
	You did not turn on the fryer, you did not set the temperature.	Use the control dial to turn on the deep fryer and set it to one of the temperatures.
	The deep fryer overheated and protection was activated.	Wait several minutes for the deep fryer to cool down and try turning it on again. If necessary, contact an authorised service centre.
Food is insufficiently cooked.	You set a temperature that is too low.	Use the control dial to increase the temperature.
	Too much food in the frying basket. The food contains remains of ice or too much moisture.	Remove some of the food. Before frying, remove the ice remains and thoroughly dry the food.
Fresh French fries are not crispy.	The crispiness of fresh French fries depends on the amount of oil and water content.	Thoroughly dry French fries before frying them. Slice them up into smaller pieces and add more oil if necessary.
The frying medium foams excessively during the deep frying process.	The food contains remains of ice or too much moisture.	Before frying, remove the ice remains and thoroughly dry the food.
	The frying medium is not suitable for frying. The frying medium has been used for too long.	Use oil or shortening fat suitable for frying. Replace the frying medium.
The deep fryer is emitting an unpleasant odour	The frying medium is no longer fresh.	Replace the frying medium.
	The frying medium is not suitable for frying.	Use oil or shortening fat recommended for frying. Do not combine various types of oil and shortening fat.

TECHNICAL SPECIFICATIONS

Rated voltage range	230 V AC
Rated frequency.....	50/60 Hz
Rated power input	900 W
Frying pot capacity	1.5 litres / 600 g of French fries
Dimensions (height x width x depth)	210 mm x 270 mm x 220 mm
Weight.....	1.9 kg

Changes to text and technical parameters are reserved.

INSTRUCTIONS AND INFORMATION REGARDING THE DISPOSAL OF USED PACKAGING MATERIALS

Dispose of used packaging material at a site designated for waste in your municipality.

DISPOSAL OF USED ELECTRICAL AND ELECTRONIC

EQUIPMENT



This symbol on products or original documents means that used electric or electronic products must not be added to ordinary municipal waste. For proper disposal, renewal and recycling, hand these products over to determined collection points. Alternatively, in some European Union states or other European countries you may return your appliances to the local retailer when buying an equivalent new appliance.

Correct disposal of this product helps save valuable natural resources and prevents potential negative effects on the environment and human health, which could result from improper waste disposal. Ask your local authorities or collection facility for more details.

In accordance with national regulations penalties may be imposed for the incorrect disposal of this type of waste.

For business entities in European Union states

If you want to dispose of electric or electronic devices, ask your retailer or supplier for the necessary information.

Disposal in other countries outside the European Union.

This symbol is valid in the European Union. If you wish to dispose of this product, request the necessary information about the correct disposal method from the local council or from your retailer.



This product meets all the basic requirements of EU directives related to it.