

# TOTAL

One-Stop Tools Station

TOTAL

## BATTERY HAMMER DRILL

TRHLI1601



# 20V

# Security instructions



## Caution

Read all safety warnings and all instructions. Failure to follow the warnings and instructions may result in electric shock, fire, and/or serious injury.

*Note: Save all warnings and instructions for future reference.* Due to our ongoing R&D&I program, the specifications in this document are subject to change without notice.

### 1) Work area safety

- a. Keep the work area clean and well lit to prevent accidents.
- b. Do not use power tools in explosive atmospheres, such as in the presence of flammable liquids, gases, or dust that can cause fires.
- c. Keep children and other unauthorized persons away while using a power tool. Distractions can cause you to lose control of the tool.

### 2) Electrical safety

- a. Power tool plugs must match the outlet. Never modify the plug in any way. Using a suitable plug reduces the risk of electric shock.
- b. Avoid bodily contact with grounded surfaces such as pipes, radiators, ranges, and refrigerators. There is an increased risk of electric shock if your body is grounded.
- c. Do not expose power tools to rain or wet conditions. Water entering a power tool will increase the risk of electrical shock.
- d. Never use the cord to carry, pull or unplug the power tool. Keep the cable away from heat or oil.
- e. When using a power tool outdoors, use an extension cord suitable for outdoor use.
- f. If using the tool in a damp location is unavoidable, use a Residual Current Device (RCD) protected supply to reduce the risk of electric shock.

### 3) Personal security

- a. Always stay alert, watch what you are doing and use common sense when using the tool.
- b. Do not use a power tool if you are tired or under the influence of medication or other substances.
- c. Wear personal protective equipment. Always wear eye protection. Protective equipment such as a dust mask, non-slip safety shoes, hard hat, or hearing protection used in the proper conditions will reduce personal injury. Also don't wear loose clothing or jewelry.
- d. Prevent the tool from turning on unintentionally. Make sure the switch is in the off position before connecting to power source and moving.
- e. Remove any adjusting wrenches or wrenches before turning on the power tool. An adjustable wrench or wrench placed in a rotating part of the power tool can cause serious injury.
- f. If devices are used for dust extraction and collection, make sure they are properly connected. Properly use these devices and you will reduce dust-related hazards.

#### 4) Use and care of battery tools

- a. Recharge the battery only with the charger specified by the manufacturer. An unsuitable charger can create a fire hazard.
- b. Use power tools only with specifically designated batteries. Use of other batteries may create a risk of injury or fire.
- c. When the batteries are not in use, keep it away from other metal objects, such as paper clips, coins, keys, nails, screws, or other small metal objects, that can make a connection from one terminal to another. Shorting the battery terminals can cause burns or fire.
- d. Abusive conditions can cause expulsion of liquid from the battery; avoid contact. If accidentally contacted, rinse immediately with water. If the liquid comes into contact with the eyes, also seek medical help. Liquid expelled from the battery can cause irritation or burns.
- e. Do not use a battery or tool that is damaged or modified. They may exhibit unpredictable behavior resulting in fire, explosion, or risk of injury.
- f. Do not expose a battery or tool to fire or excessive heat. Exposure to fire or temperature above 130°C may cause an explosion.
- g. Follow all charging instructions. Do not charge the battery or tool outside the temperature range specified in the instructions. Improper charging or charging at temperatures outside the specified range may damage the battery or increase the risk of fire.

#### 5) Service

- a. Have your power tool serviced by a qualified person and use replacement parts recommended by the manufacturer. This will ensure that the safety of the power tool is maintained.
- b. Never use damaged batteries. Battery packs should only be serviced by the manufacturer or authorized service providers.

## Safety rules for correct use



Double insulation for additional protection



Please read the instruction manual before use.



CE conformity.



Wear safety glasses, hearing protection and a dust mask.



Waste electrical products or batteries must not be disposed of with household waste. Please recycle at the appropriate facilities. Check with your local authority or retailer for recycling advice.



Security alert. Use only accessories supported by the manufacturer.

# Additional security warnings

## Hammer Safety Warnings

- Wear ear protectors. Exposure to noise can cause hearing loss.
- Use auxiliary handles, if supplied with the tool. Loss of control can cause personal injury.
- Hold power tool by insulated gripping surfaces when performing an operation where the cutting accessory may contact hidden wiring or its own cord.
- The cutting accessory coming into contact with a live cable could cause an electric shock to the operator.
- When working with the machine, always hold it firmly with both hands and stand firm.
- During work breaks or when you are not using the tool (for example, changing work tools, repairs, cleaning, adjustment), disconnect the tool from the battery.
- Unqualified people cannot use this tool.
- Keep tool accessories out of the reach of children.
- Use only original accessories recommended by the manufacturer.

## Other risks

Even when the power tool is used as prescribed, it is not possible to eliminate all residual risk factors:

- a. Health defects resulting from vibration emission if the power tool is used for a longer period of time or if it is not managed and maintained properly.
- b. Injuries and property damage due to broken fixtures breaking suddenly.



### Caution

This power tool produces an electromagnetic field during operation. This field can, in some circumstances, interfere with active or passive medical implants.

To reduce the risk of serious injury, we recommend that persons with medical implants consult their physician before using this power tool.



The machine must not be damp and must not be used in a humid environment.



### Attention

Safe operation of this machine is only possible when the operating or safety information is fully read and the instructions contained therein are strictly followed.



## Technical data

Data sheet	
<b>Voltage</b>	20V
<b>Drilling capacity in concrete (optimal depth)</b>	16mm (80mm)
<b>Steel drilling capacity</b>	13mm
<b>Wood drilling capacity</b>	42mm

## Product description

1. locking sleeve
2. mode selector switch
3. Variable speed controlled trigger switch
4. Forward/reverse lever and trigger lock
5. Mango
6. Battery (not included)
7. Battery extraction switch
8. Integrated LED work light
9. dust cap



*Note: The machine is designed for impact drilling in concrete, brick and stone. It is also suitable for non-impact drilling in wood, metal, ceramics and plastic.*

*Note 2: Not all accessories illustrated or described may not be included in the standard delivery.*

# Set up



## Attention

Disconnect the battery pack from the tool or place the switch in the locked or off position before making any mounting, adjustments, or changing accessories. These preventative safety measures reduce the risk of the tool being started accidentally.

## Mounting

### Installation of accessories (Fig. 2)

- Clean the end of the bit to remove any debris.
- Then lightly grease with a light oil or lubricant.
- Insert the accessory into the chuck through the dust shield, while twisting and pushing in until it automatically locks into place.
- Pull out on the accessory to make sure it is properly seated in the chuck.

### Remove accessories (Fig. 3)

- Accessories (bits) may be hot after use.
- Avoid skin contact and wear suitable protective gloves or cloth to remove.
- To remove an accessory, pull the locking sleeve back and pull the bit forward. All accessories should be wiped clean after removal.

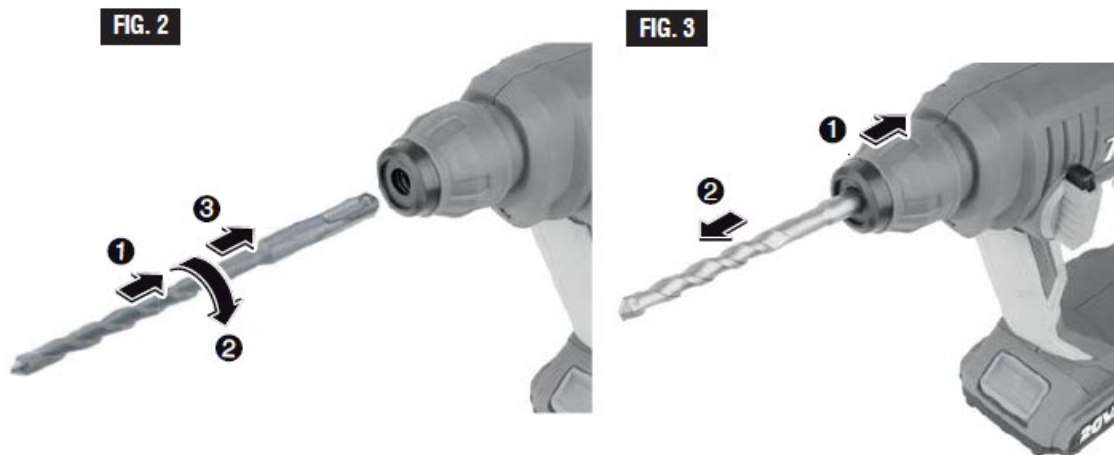

## Set up

### Trigger switch with variable speed control (3)

Your tool is equipped with a variable speed trigger switch. The tool can be turned on or off by squeezing or releasing the trigger. The speed can be adjusted from the minimum RPM to the maximum listed on the nameplate by the pressure you apply to the trigger. Apply more pressure to increase speed and release pressure to decrease speed.

### Forward/reverse lever and trigger lock (4)

Your tool is equipped with a forward/reverse lever and trigger lock located above the trigger (Fig. 4).

This lever was designed to change chuck rotation and to lock the trigger in the "OFF" position to help prevent accidental starts and accidental battery discharge.

- **For forward rotation:** With the chuck pointed away from you, move the lever to the far left.
- **For reverse rotation:** Move the lever to the extreme right. To activate the trigger lockout, move the lever to the center off position.



## Caveat

Do not change the direction of rotation until the tool comes to a complete stop. Shifting during chuck rotation can damage the tool.

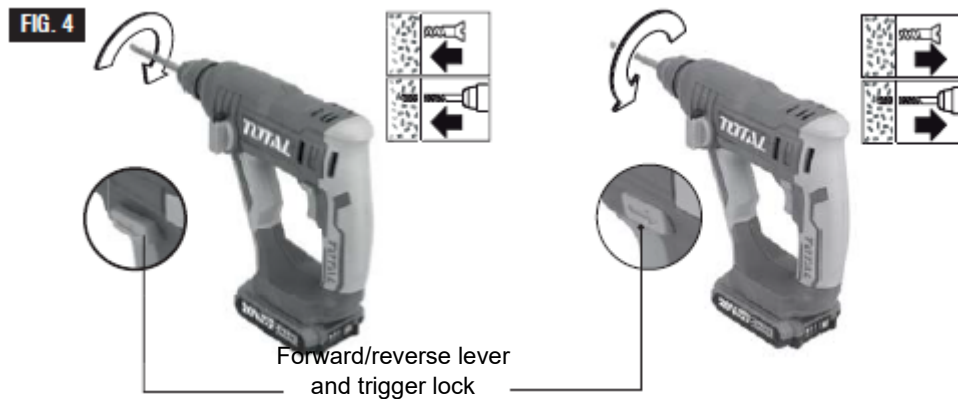

## Mode selection switch: drill/hammer (2)

The dial/selector switch allows the tool to be configured for various drilling/hammer drilling applications.

Turn the selector dial clockwise or counterclockwise depending on the following applications.



drill action: for drilling in wood, metal, plastic or other similar materials.



Hammer action drill (hammer action): For drilling in concrete, asphalt, tile or other similar hard materials.



## Caution

Do not use the selection switch until the tool comes to a complete stop. Shifting during chuck rotation can damage the tool.

Do not use demolition or chipping bits such as bull points, chisels, shovels, etc.

## Brake

When the trigger is released, it activates the electric brake to stop the chuck quickly. This is especially helpful in repetitive screw driving and removal.

## Inserting and unlocking the battery pack (6 and 7)

- Set the forward/reverse lever (4) to the center (off position).
- Slide the charged battery pack into the case until it clicks into position (Fig. 5).
- To remove the battery pack, press the battery pack release button and slide the battery pack forward.



## Work tips

Following a few simple tips will reduce tool wear and the possibility of operator injury.

- The high efficiency available from rotary hammers can only be obtained if sharp and well-maintained accessories are used.
- All hammers require a short period of time to warm up. Depending on the ambient temperature, this time can vary from approximately 15 seconds (90F) to 2 minutes (32F).
- A new hammer requires a break-in period before full performance is achieved. This period may require up to 5 hours of operation.
- To prolong the life of bits, bring the bit into contact with the workpiece before you pull the trigger.
- During operation, hold the drill firmly and apply moderate and constant pressure.
- Too much pressure at low speed will stop the hammer. Too little pressure will prevent the bit from cutting and will cause excess friction as it slides over the surface. This can damage the drill and bit.
- Carbide Tipped Drill Bits - Used for drilling stone, concrete, cement, brick, cinder block, and other unusually hard non-metallic materials.
- The snags on all bits should be cleaned before use and immediately after removal.

Remember these instructions for safe operation:

- All work must be supported or secured before drilling and constant, even pressure must be applied in line with the bit.
- As the bit passes through the opposite side, reduce pressure and continue to run the drill while the bit is withdrawn.
- Some materials require slow drilling speeds; while others require higher speed to produce the best results. Materials such as glass, porcelain, ceramics, tiles, plastics, etc., should be drilled at low speed with specially designed drill bits and lubricants.

### Drilling mode: drilling in wood or plastic

If a backing block is not used, ease off the pressure just before the bit goes through the wood to prevent splintering. Complete the hole from the opposite side immediately after the tip opens. If the bit binds, reverse the drilling operation to help remove the bit from the work.

### Drilling mode: metal

There are two rules for drilling hard materials:

- First, the harder the material, the more pressure you need to apply to the tool.



- Second, the harder the material, the slower the speed.

Here are a couple of tips for drilling in metal:

- Punch a hole in the center of the material to make starting easier.
- Lubricate the tip of the bit from time to time with cutting oil, except when drilling soft metals such as aluminum, copper, or cast iron.
- If the hole to be drilled is quite large, drill a smaller hole first, then enlarge to the required size, often faster in the long run.
- Maintain enough pressure to ensure the bit does not spin in the hole. Otherwise, it will dull the drill bit and greatly shorten its life.

### Masonry drilling

Use a carbide-tipped masonry bit for concrete block, mortar, common brick, soft stone, and other materials. The amount of pressure to use depends on the type of material being drilled. Soft materials require less pressure, while hard materials require more pressure to keep the bit from turning.

## Maintenance

### For safe operation

- Always keep the machine and the ventilation slots clean.
- Clean the tool holder daily.

### Replacing the dust cap

Damaged dust caps should be replaced as dust seeping into the chuck can cause tool errors.

- Pull back and hold the locking sleeve.
- Remove the dust cap with a suitable tool.
- With the locking sleeve removed, pull on the new cap until it is seated firmly on the collet and the locking sleeve can slide forward again.

Should the machine fail despite the care taken in manufacturing and testing, contact your official Total dealer.

## Environment



- Do not dispose of electrical appliances as unsorted municipal waste, use separate collection facilities.
- Contact your local authority for information on available collection systems.
- If electrical appliances are disposed of in landfills, hazardous substances can seep into the groundwater and enter the food chain, harming your health and well-being.
- Recycle raw materials instead of disposing of them as waste.
- The machine, accessories and packaging must be sorted for environmentally friendly recycling.
- Plastic components are labeled for categorized recycling.

# Exploded view

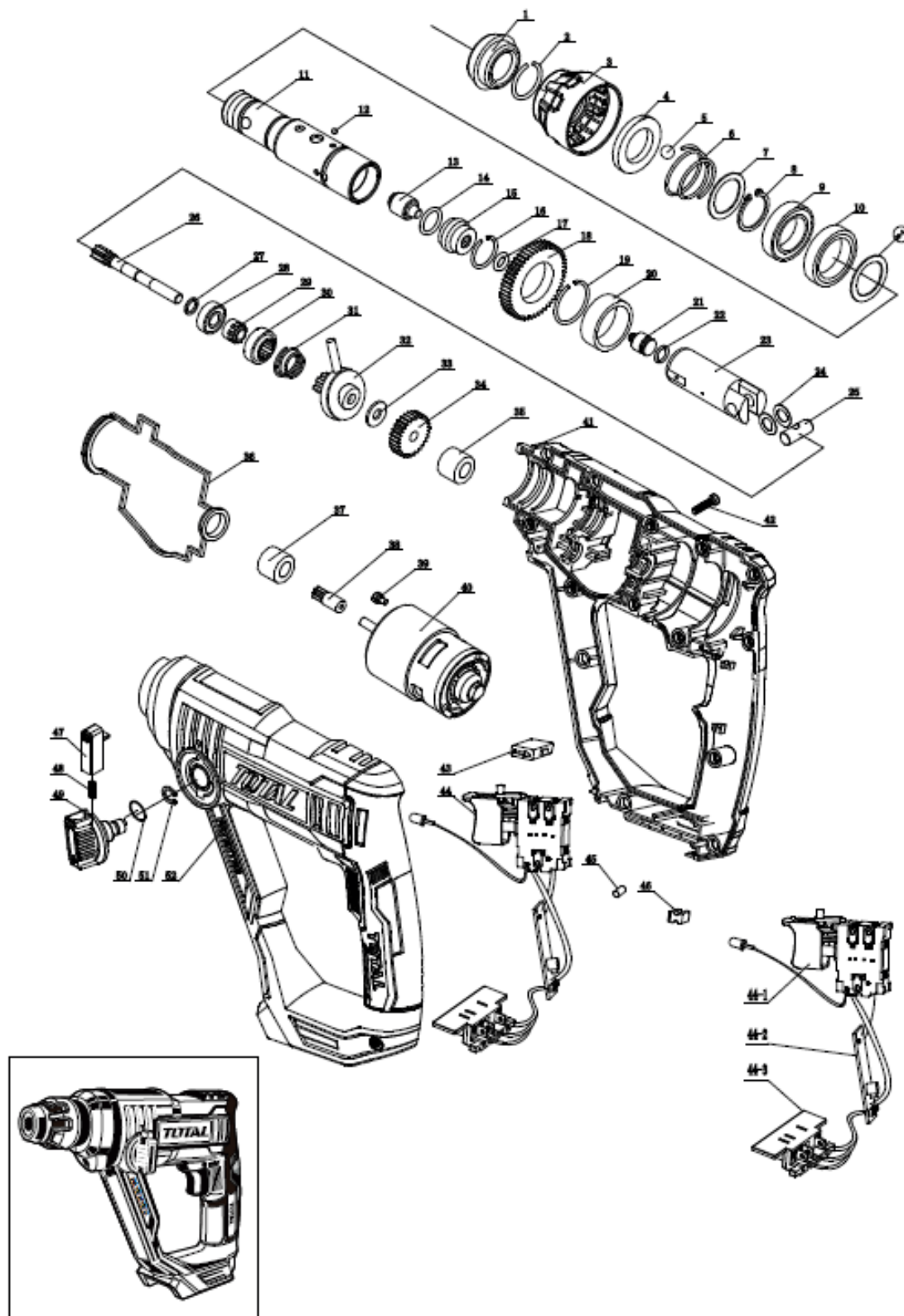

# TOTAL

One-Stop Tools Station

TOTAL



**BATTERY HAMMER DRILL**

**20V**