

FINLUX

6;

#

9B : fYY`GhUbX]b[`7cc_Yf`#l gYf`AUbi U

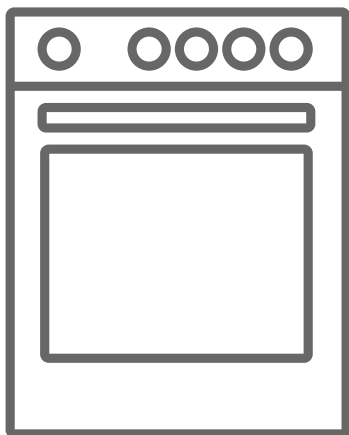

: L7 `* &&A
: L7 `) &&A

FÈ		Á Á	Á
FÈÁ	Á	Á Á	Á
FÈÁ		Á Á	Á
FÈÁ	Á	Á Á	Á
FÈÁ	Á	Á Á	Á
GÈ	Á Á	Á Á	Á
GÈÁ	Á Á		Á
GÈÁ	Á Á		Á
GÈÁ	Á		Á
GÈÁ		Á Á Ç Á	Á
GÈÁ		Á Á	Á
GÈÁ	Á	Á	Á
GÈÁ	Á Á		Á
HÈ		Á Á	Á
IÈ		Á Á	Á
IÈÁ		Á Á	Á
IÈÁ		Á Á	Á
IÈÁ	Á Á	Á Á	Á
IÈÁ	Á Á	Á	Á
IÈÁ			Á
ÍÈ		Á Á	Á
ÍÈÁ			Á
ÍÈÁ			Á
ÍÈÁ			Á
ÎÈ		Á Á	Á Á
ÎÈÁ		Á Á	Á Á
ÎÈÁ			Á Á
ÏÈ		Á	
ÏÈÁ	Á Á	Á Á	Á Á
ÏÈÁ	Á Á	Á Á	Á Á
ÏÈÁ	Á		
ÏÈÁ	Á		
ÏÈÁ	Á		



Á Á



Á Á



Á Á

“

Á Á

”

Á Á



Á Á

“

Á Á

”

Á Á

”

Á Á

“ Á Á Á Á Æ Á Á Á É
Æ Á Á Á Á Á Á Á Á Á Á
Á Á Á Á Á Á Á Á Á Á



Á Á Á Á Á Á Á Á Á Á Á Á
Á Á Á Á Á Á Á Á Á Á Á Á

“ Á Á Á Á Á Á Á Á Á Á Á Á
Á Á Á Á Á Á Á Á Á Á Á Á

% (.

“ Á Æ Á Á Á Á Á Á Á Á Á Á
Á Á Á Á Á Á Á Á Á Á Á Á

“ Á Á Á Á Á Á Á Á Á Á Á Á
Á Á Á Á Á Á Á Á Á Á Á Á

“ Á Á Á Á Á Á Á Á Á Á Á Á
Á Á Á Á Á Á Á Á Á Á Á Á Á Á Á Á
Á Á Á Á Á Á Á Á Á Á Á Á Á Á Á Á

9
C E Á Á Á Á Á Á Á Á Á Á Á Á
Æ Á Á Á Á Á Á Á Á Á Á Á Á Á Á
Á Á Á Á Á Á Á Á Á Á Á Á Á Á Á Á
Á Á Á Á Á Á Á Á Á Á Á Á Á Á Á Á



Á

Ë

Á

Á

Á

Á

Á

Á

Á

Á

Á

Á

Á

È

Á

Á

Á



Á

Á

Á

Á

Á

Á

Á

Á

Á

Á

Á

Á

Ë

Á

Á

Á

Ë

Á

Á

Á

Á

Á

Á

Á

Á

Á

Á

Á

Á

Á

Á

Á

Á

Á

Á

Ë

Á

Á

Á

Á

Á

Á

Á

Á

Á

Á

Á

Á

Á

Á

Á

Ë

Á

Á

Á

Á

Á

Ë

Á

Á

Á

Á

Á

Á

Á

Á

Á

Á

Á

Á

Á

Á

Á

Á

Á

Ë

Á

Á

Ë

Á

Á

Á

Á

Á

Á

Ë

Á

Á

Á

È

Á

Á

Á

Á

Á Á Á È
 " Á Á Á Á Á Á Á
 " Á Á Á Á Á Á Á È
 " Á Á Á Á Á Á Á È
 Á Á Á Á Á Á Á È
 Á Á Á Á Á Á Á È
 È

Á Á Á Á Á Á Á È Á
 " Á Á Á Á Á Á Á È Á
 " Á Á Á Á Á Á Á È
 " Á Á Á Á Á Á Á È
 Á Á Á Á Á Á Á È Á Á È È

&''

Á Á Á Á Á Á Á È
 " Á Á Á Á Á Á Á È

5 'fb a Ł		Ł
6 'fb a Ł	#	Ł Ł
7 'fb a Ł		Ł
8 'fb a Ł		Á Á
9 'fb a Ł		Ł

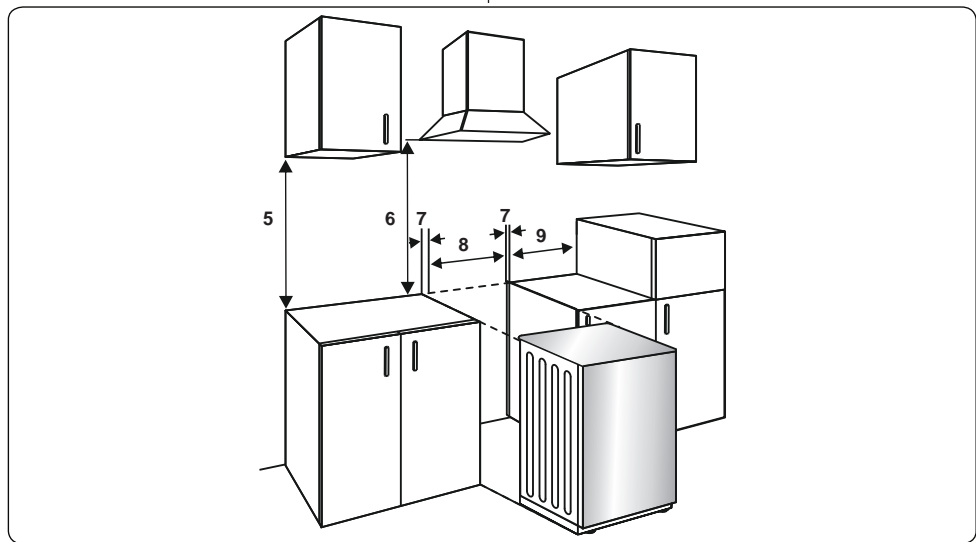

&''

Á Á Á Á Á Á Á È
 " Á Á Á Á Á Á Á È
 " Á Á Á Á Á Á Á È
 " Á Á Á Á Á Á Á È
 Á Á Á Á Á Á Á È
 Á Á Á Á Á Á Á È
 Á Á Á Á Á Á Á È

Á Á Á Á Á Á Á È Á
 " Á Á Á Á Á Á Á È Á
 " Á Á Á Á Á Á Á È
 " Á Á Á Á Á Á Á È
 Á Á Á Á Á Á Á È Á Á È È

&*'

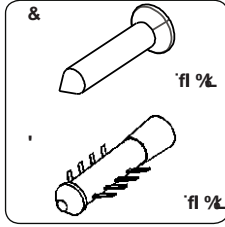
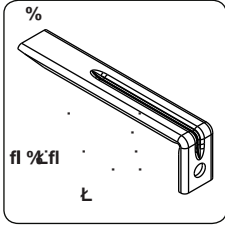

&*'

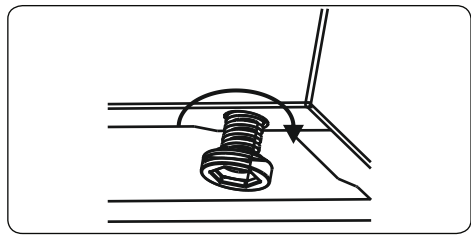
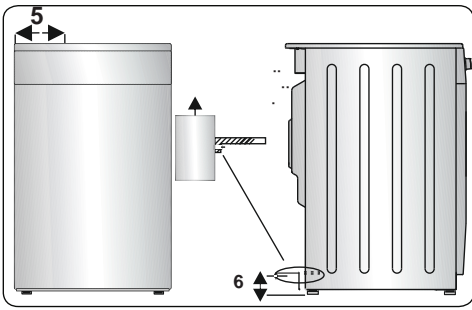

fl	L	L fl a L	5 'fb a L	6 'fb a L
í éí éwéç	Á	D	G İ Ę	í G
í éí éwéç	Á	D	G İ Ę	í G
J éí éí í			I H E	F E Ĭ
í éí éwéÁ			H E Ĭ	F F G
í éí éí í			H E Ĭ	î I
í éí éwé			G İ Ę	F F G
í éí éí í			G İ Ę	î I
í éí éwé			G İ Ę	F F G
í éí éí í			G İ Ę	î I



Á Á .Á

Á Á

Á Á Á Á

Á Á

Á Á Á Á
E

Á Á

Á

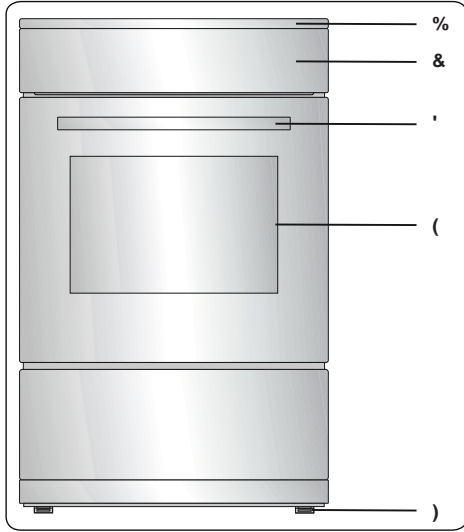

%
&"
'"
("
)"

Á
Á
Á Á
Á Á
Á

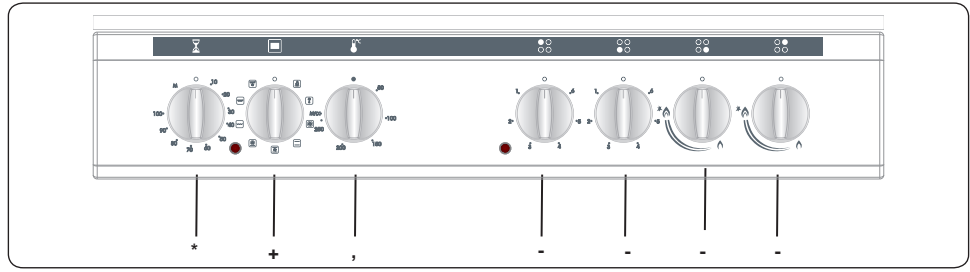

* "

+ "

, "

- "

Á Á
Á Á
Á Á

Á Á
Á Á
Á Á

Á Á

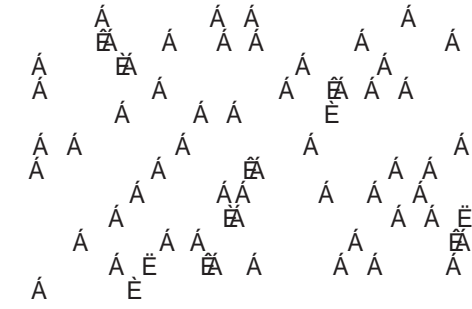

Á	Đ	Á	GG	Á
È	Á		FI	Á
Á	K		FG	Á

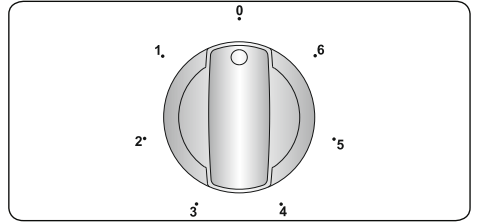
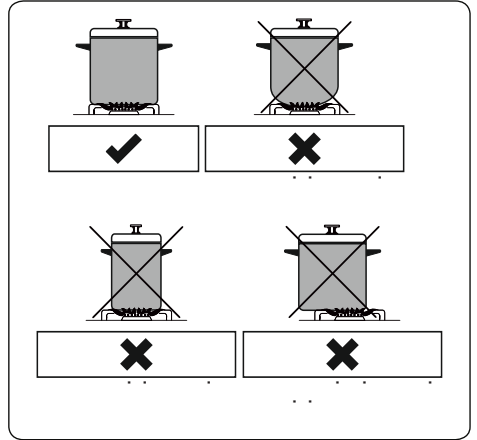
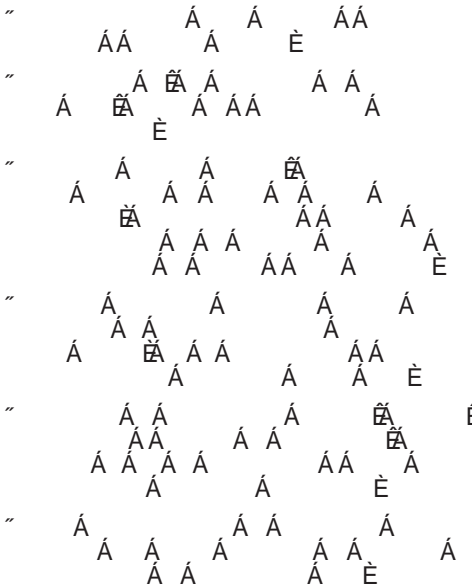
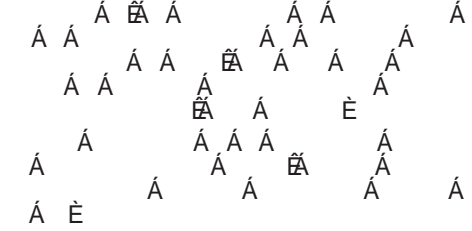

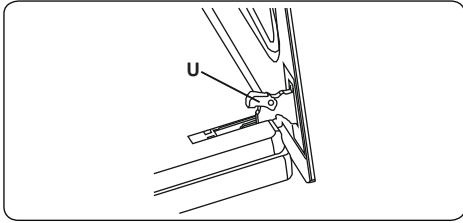

Á Á Á É Á Á Á
 Á Á Á É Á Á Á

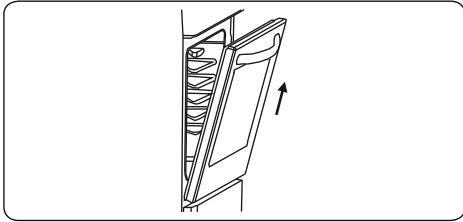

) "8'



Á Á Á Á Á Á Á Á Á
 Á Á Á Á Á Á Á Á Á



Á Á Á Á Á Á Á Á Á Á
 Á Á Á Á Á Á Á Á Á Á
 Á Á Á Á Á Á Á Á Á Á
 Á Á Á Á Á Á Á Á Á Á
 Á Á Á Á Á Á Á Á Á Á
 Á Á Á Á Á Á Á Á Á Á



Á Á Á Á Á Á Á Á Á Á
 Á Á Á Á Á Á Á Á Á Á
 Á Á Á Á Á Á Á Á Á Á

) "''



Á Á Á Á Á Á Á Á Á Á
 Á Á Á Á Á Á Á Á Á Á
 Á Á Á Á Á Á Á Á Á Á
 Á Á Á Á Á Á Á Á Á Á
 Á Á Á Á Á Á Á Á Á Á
 Á Á Á Á Á Á Á Á Á Á
 Á Á Á Á Á Á Á Á Á Á
 Á Á Á Á Á Á Á Á Á Á
 Á Á Á Á Á Á Á Á Á Á
 Á Á Á Á Á Á Á Á Á Á
 Á Á Á Á Á Á Á Á Á Á
 Á Á Á Á Á Á Á Á Á Á
 Á Á Á Á Á Á Á Á Á Á
 Á Á Á Á Á Á Á Á Á Á

+

+%

fi L7') &&A 'L

<p>ÖHEÁÍ ÈÈÈ, ààÀ Á È Á Y / ÀÁÁ Á Á ÈÁ ÖPHÓB/ÁÁÁÁÁÁ Á Á</p>	<p>pOÁ ÖGÉÁ ààÁ</p>	<p>SUÓÁ ÖHEÁÍ ÈÈÈ àà</p>
Á		
Á F È É Á { D	FFÍ	íí
Á S Y D	GÈ	H
Á @	G í Á @	G F Í È Á @
Á		
Á F È É Á { D	Jí	íí
Á S Y D	FÉ í	FÉ í
Á @	F í í È Á @	F G Í È Á @

+ "8:

'fl L7 * &&A 'L

ÖHEÁĠ ĘHEĀ àæÁĚ ĘÁY ÁÁÁÁ Ĩ Á BĠÁ ÖP HÖBĀ/ÁÁÖÖ/ÁÁÁÁ ĤF	P ÖÁ ÖGE/ÖEĀ àæÁ	ŠÚÖÁ ÖHEÁĠ ĘHEĀ àæ
Á		
ÁĤĤĤĤĤ { D	FFÍ	ìí
ÁŠY D	ĠĚÍ	H
ÁĤ@	Ġ FĀ ÁĤ@	ĠFĀ ĘÁ Ĥ@
Á		
ÁĤĤĤĤĤ { D	Jĭ	îí
ÁŠY D	FĚÍ	FĚÍ
ÁĤ@	Fĭ Ĩ Ę ÁĤ@	FĠ ĘÁ Ĥ@

+''

		FINLUX
		ØÝÓÁ GGT
Á Á		Ò
	*	HJË
Á Á ÆÁ Á		FEË
Á Á ÆÁÁ		JHË
Á		CE
/Ç DÆÁ Á	\Y @	€Ë J
/Ç DÆÁÁ	\Y @	€Ë F
Á		F
Á		Ò
		í€
Á Á Á ÖPÁ HÍ €ÆÁ		

Á Á Á Á Á
ÆÁ Á Á ÆÁ ÁÁ È
ÆÁ Á Á Á Á Á È
ÆÁ Á Á Á Á È
ÆÁ Á Á Á Á Á Á È
ÆÁ Á Á Á Á Á Á È

+")

		FINLUX			
		ØYÔÂ GGT			
Á Á		Ò			
	*	Í Î			
Á Á	ÄÄ	Á	FÉ Î		
Á Á	ÄÄÄ		JÍ Î		
Á			Œ		
	Ï	ÄÄ	Á	\Y @	Ë Î
	Ï	ÄÄÄ		\Y @	Ë Î
Á					F
Á					Ò
					Î Î
Á Á	Á	ÄÄÄ	ÄÄÄ		

Á Á	Á Á	Á
ÄÄ	ÄÄ	ÄÄ
ÄÄ	ÄÄ	ÄÄ
ÄÄ	ÄÄ	ÄÄ
ÄÄ	ÄÄ	ÄÄ
ÄÄ	ÄÄ	ÄÄ
ÄÄ	ÄÄ	ÄÄ

+)"





		FINLUX
		ØY ÓÁ GGT ØY ÓÁ GGT
Á Á		
Á Á Á Á		I
Á ÆÆ		
ÆÆ	&	È
ÆÆ	Ã	Í J Æ
Á ÆÆG		
ÆG		
ÆÆG	Ã	í ï Æ
Á ÆÆH		Á
ÆH	&	< F I È
ÆÆH	Y @*	F J H È
Á ÆÆ		Á
ÆÆ	&	< F I È
ÆÆ	Y @*	F J I È
Á Á	Y @*	F J H È
Á Á	Ã	í ï Æ
Á Á Ó Á È Í È Ó Á H È È		

	Á Á	Á Á	Á		
ÆÆ	Á	Á	Á Á	Á	È
ÆÆ	Á	Á	Á Á	Á	È
ÆÆ	Á	Á	Á Á	È	
ÆÆ	Á	Á Á	Á Á	Á Á	È
ÆÆ	Á	Á Á	Á	Á	È

HA Üb_ nci 'Zf'W ccg]b['h]g'dfcXi Wf'

This User Manual contains important safety information and instructions on the operation and maintenance of your appliance. A

Please take the time to read this User Manual before using your appliance and keep this book for future reference.

=Vc b	HrdY	A YÜb]b[
	K 5 FB-B;	Ü^!q ~ •Ä b;^ Ä !Ä^æ@Ä\
	F=G? 'C: '9 @7 HF 7 'G< C7 ?	Öæ *^! ~ •Ä] æ^Ää\
	: -F9	Warning; Risk of fire / flammable materials
	7 5 I H-CB	Injury or property damage risk
	-A DCFH5 BH#BCH9	Operating the system correctly

CONTENTS

1.SAFETY INSTRUCTIONS.....	4
1.1 General Safety Warnings	4
1.2 Installation Warnings	7
1.3 During Use	8
1.4 During Cleaning and Maintenance	10
2.INSTALLATION AND PREPARATION FOR USE.....	12
2.1 Instructions for the Installer	12
2.2 Installation of the Cooker	13
2.3 Gas Connection.....	13
2.4 Gas Conversion (if available)	14
2.5 Electrical Connection and Safety (if available)	15
2.6 Anti-tilting kit	16
2.7 Adjusting the feet	16
3.PRODUCT FEATURES	18
4.USE OF PRODUCT	19
4.1 Use of gas burners	19
4.2 Hob Controls.....	19
4.3 Oven Controls.....	21
4.4 Use of the Mechanical Timer	22
4.5 Accessories	22
5.CLEANING AND MAINTENANCE.....	23
5.1 Cleaning	23
5.2 Maintenance.....	25
5.3 Maintenance.....	25
6.TROUBLESHOOTING&TRANSPORT	26
6.1 Troubleshooting.....	26
6.2 Transport	27
7.TECHNICAL SPECIFICATIONS.....	28
7.1 Injector Table(FXC 522M).....	28
7.2 Injector Table(FXC 622M).....	29



1. SAFETY INSTRUCTIONS

- Carefully read all instructions before using your appliance and keep them in a convenient place for reference when necessary.
- This manual has been prepared for more than one model therefore your appliance may not have some of the features described within. For this reason, it is important to pay particular attention to any figures whilst reading the operating manual.

1.1 General Safety Warnings

- This appliance can be used by children aged from 8 years and above and by persons with reduced physical, sensory or mental capabilities or lack of experience and knowledge if they have been given supervision or instruction concerning use of the appliance in a safe way and understand the hazards involved. Children should not play with the appliance. Cleaning and user maintenance should not be made by children without supervision.

 **WARNING:** The appliance and its accessible parts become hot during use. Care should be taken to avoid touching heating elements. Keep children less than 8 years of age away unless they are continually supervised.

  **WARNING:** Unattended cooking on a hob with fat or oil can be dangerous and may result in fire. NEVER try to extinguish such a fire with water, but switch off the appliance and cover the flame with a lid or a fire blanket.

 **CAUTION:** The cooking process has to be supervised. A short term cooking process has to be supervised continuously

 **WARNING:** Danger of fire: Do not store items on the cooking surfaces.

 **WARNING:** If the surface is cracked, switch off the appliance to avoid the possibility of electric shock.

- For models which incorporate a hob lid, clean any spillages off the lid before use and allow the cooker to cool before closing the lid.
- Do not operate the appliance with an external timer or separate remote-control system.

 **WARNING:** To prevent the appliance tipping, the stabilising brackets must be installed. (For detailed information refer to the anti-tilting kit set guide.)



- During use the appliance will get hot. Care should be taken to avoid touching heating elements inside the oven.
- Handles may become hot after a short period during use.
- Do not use harsh abrasive cleaners or scourers to clean oven surfaces. They can scratch the surfaces which may result in shattering of the door glass or damage to surfaces.
- Do not use steam cleaners to clean the appliance.

 **WARNING:** To avoid the possibility of electric shock, make sure that the appliance is switched off before replacing the lamp.

 **CAUTION:** Accessible parts may be hot when cooking or grilling. Keep young children away from the appliance when it is in use.

- Your appliance is produced in accordance with all

applicable local and international standards and regulations.

- Maintenance and repair work should only be carried out by authorised service technicians. Installation and repair work that is carried out by unauthorised technicians may be dangerous. Do not alter or modify the specifications of the appliance in any way. Inappropriate hob guards can cause accidents.
- Before connecting your appliance, make sure that the local distribution conditions (nature of the gas and gas pressure or electricity voltage and frequency) and the specifications of the appliance are compatible. The specifications for this appliance are stated on the label.

 **CAUTION:** This appliance is designed only for cooking food and is intended for indoor domestic household use only. It should not be used for any other purpose or in any other application, such as for non-domestic use, in a commercial environment or for heating a room.

- Do not use the oven door handles to lift or move the appliance.
- This appliance is not connected to a ventilation device. It should be installed and connected in accordance with current installation regulations. Particular attention shall be given to the relevant requirements regarding ventilation.
- If the burner has not lit after 15 seconds, stop operating the device and open the compartment door. Wait at least 1 minute before attempting to ignite the burner again.
- These instructions are only valid if the correct country symbol appears on the appliance. If the symbol does not appear on the appliance, refer to

the technical instructions which describe how to modify the appliance to match the conditions of use of the country.

- All possible measures have been taken to ensure your safety. Since the glass may break, care should be taken while cleaning to avoid scratching. Avoid hitting or knocking the glass with accessories.
- Make sure that the supply cord is not trapped or damaged during installation. If the supply cord is damaged, it must be replaced by the manufacturer, its service agent or similarly qualified persons in order to prevent a hazard.
- Do not let children climb on the oven door or sit on it while it is open.
- If your appliance is provided with a cooking hotplate made of glass or glass ceramic:
 **CAUTION:** “In case of hotplate glass breakage”:
 - immediately shut off all burners and any electrical heating element and isolate the appliance from the power supply
 - do not touch the appliance surface
 - do not use the appliance.
- Please keep children and animals away from this appliance.

1.2 Installation Warnings

- Do not operate the appliance before it is fully installed.
- The appliance must be installed by an authorised technician. The manufacturer is not responsible for any damage that might be caused by incorrect placement and installation by unauthorised people.
- When the appliance is unpacked, make sure that it has not been damaged during transportation.

In the case of a defect do not use the appliance and contact a qualified service agent immediately. The materials used for packaging (nylon, staplers, styrofoam, etc.) may be harmful to children and they should be collected and removed immediately.

- Protect your appliance from the atmosphere. Do not expose it to sun, rain, snow, dust or excessive humidity.
- Materials around the appliance (i.e. cabinets) must be able to withstand a minimum temperature of 100°C.
- The appliance must not be installed behind a decorative door, in order to avoid overheating.

1.3 During Use

- When you first use your oven you may notice a slight smell. This is perfectly normal and is caused by the insulation materials on the heater elements. We suggest that, before using your oven for the first time, you leave it empty and set it at maximum temperature for 45 minutes. Make sure that the environment in which the product is installed is well ventilated.
- Take care when opening the oven door during or after cooking. The hot steam from the oven may cause burns.
- Do not put flammable or combustible materials in or near the appliance when it is operating.
- Always use oven gloves to remove and replace food in the oven.



Do not leave the cooker unattended when cooking with solid or liquid oils. They may catch fire under extreme heating conditions. Never pour water on to flames that are caused by oil, instead switch the

cooker off and cover the pan with its lid or a fire blanket.

- Always position pans over the centre of the cooking zone, and turn the handles to a safe position so they cannot be knocked.
- If the product will not be used for a long period of time, turn the main control switch off. Turn the gas valve off when gas appliances are not in use.
- Make sure the appliance control knobs are always in the “0” (stop) position when the appliance is not in use.
- The trays incline when pulled out. Take care not to spill or drop hot food when removing it from the oven.

 **CAUTION:** The use of a gas cooking appliance results in the production of heat, moisture and products of combustion in the room in which it is installed. Ensure that the kitchen is well ventilated especially when the appliance is in use, keep natural ventilation holes open or install a mechanical ventilation device (mechanical extractor hood).

- Prolonged intensive use of the appliance may call for additional ventilation, such as opening a window, or for more effective ventilation, for example by increasing the level of mechanical ventilation where present.
- While using the grill burner, keep the oven door open and always use the grill deflector shield supplied with the product. Never use the grill burner with the oven door closed.

 **CAUTION:** Glass lids may shatter when heated. Turn off all the burners and allow the hob surface to cool before closing the lid.



- Do not place anything on the oven door when it is open. This could unbalance the oven or damage the door.
- Do not place heavy or flammable items (e.g. nylon, plastic bags, paper, cloth, etc.) into the drawer. This includes cookware with plastic accessories (e.g. handles).

 **CAUTION:** The inside surface of the storage compartment may get hot when the appliance is in use. Avoid touching the inside surface.

- Do not hang towels, dishcloths or clothes from the appliance or its handles.

1.4 During Cleaning and Maintenance

- Make sure that your appliance is turned off at the mains before carrying out any cleaning or maintenance operations.
- Do not remove the control knobs to clean the control panel.
- To maintain the efficiency and safety of your appliance, we recommend you always use original spare parts and to call our authorised service agents when needed.

CE Declaration of conformity

 We declare that our products meet the applicable European Directives, Decisions and Regulations and the requirements listed in the standards referenced.

This appliance has been designed to be used only for home cooking. Any other use (such as heating a room) is improper and dangerous.

 The operating instructions apply to several models. You may notice differences between these instructions

and your model.

Disposal of your old machine

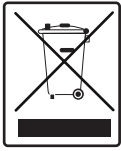

This symbol on the product or on its packaging indicates that this product should not be treated as household waste. Instead it should be handed over to the applicable collection point for the recycling of electrical and electronic equipment. By ensuring this product is disposed of correctly, you will help prevent potential negative consequences for the environment and human health, which could otherwise be caused by inappropriate waste handling of this product. For more detailed information about recycling of this product, please contact your local city office, your household waste disposal service or the retailer who you purchased this product from.

2. INSTALLATION AND PREPARATION FOR USE

WARNING : This appliance must be installed by an authorised service person or qualified technician, according to the instructions in this guide and in compliance with the current local regulations.

- Incorrect installation may cause harm and damage, for which the manufacturer accepts no responsibility and the warranty will not be valid.
- Prior to installation, ensure that the local distribution conditions (electricity voltage and frequency and/or nature of the gas and gas pressure) and the adjustments of the appliance are compatible. The adjustment conditions for this appliance are stated on the label.
- The laws, ordinances, directives and standards in force in the country of use are to be followed (safety regulations, proper recycling in accordance with the regulations, etc.).

2.1 Instructions for the Installer

Ventilation requirements

- For rooms with a volume of less than 5 m³, permanent ventilation of 100 cm² free area is required.
- For rooms with a volume of between 5 m³ and 10 m³, permanent ventilation of 50 cm² free area will be required, unless the room has a door which opens directly to outside air in which case no permanent ventilation is required.
- For rooms with a volume greater than 10 m³, no permanent ventilation is required.

Important: Regardless of room size, all rooms containing the appliance must have direct access to outside air via an openable window or equivalent.

Emptying of burned gases from the environment

Gas appliances expel burned gas waste to the outside air, either directly or via a cooker hood with a chimney. If it is not possible to install a cooker hood, install a fan on the window or wall that has access to fresh air. The fan must have the capacity to change the volume of air in the kitchen a minimum of 4-5 times per hour.

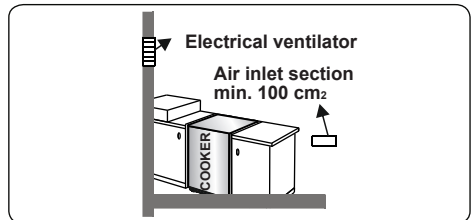
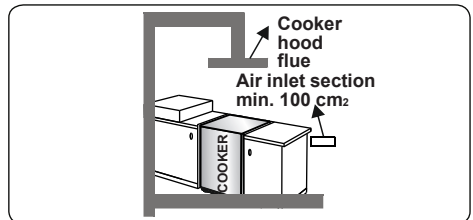
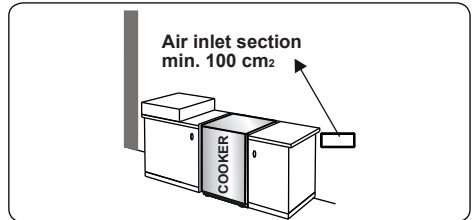
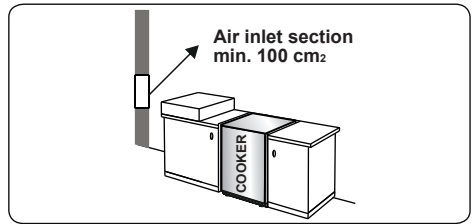

General instructions

- After removing the packaging material from the appliance and its accessories, ensure that the appliance is not damaged. If you suspect any damage, do not use it and contact an authorised service person or qualified technician immediately.
- Make sure that there are no flammable or combustible materials in the close vicinity, such as curtains, oil, cloth etc. which may catch fire.
- The worktop and furniture surrounding the appliance must be made of materials resistant to temperatures above 100°C.

- The appliance should not be installed directly above a dishwasher, fridge, freezer, washing machine or clothes dryer.
- The appliance can be placed close to other furniture on condition that, in the area where the appliance is set up, the furniture's height does not exceed the height of the cooktop.

2.2 Installation of the Cooker

- If the kitchen furniture is higher than the cooktop, the kitchen furniture must be at least 10 cm away from the sides of appliance for air circulation.

- There should be a minimum 2cm blank space around the appliance for air circulation.
- If a cooker hood or cupboard is to be installed above the appliance, the safety distance between cooktop and any cupboard/cooker hood should be as shown below.

A (mm) Cupboard	420
B (mm) Cooker Hood	650/700
C (mm)	20
D (mm)	Product Width
E (mm)	100

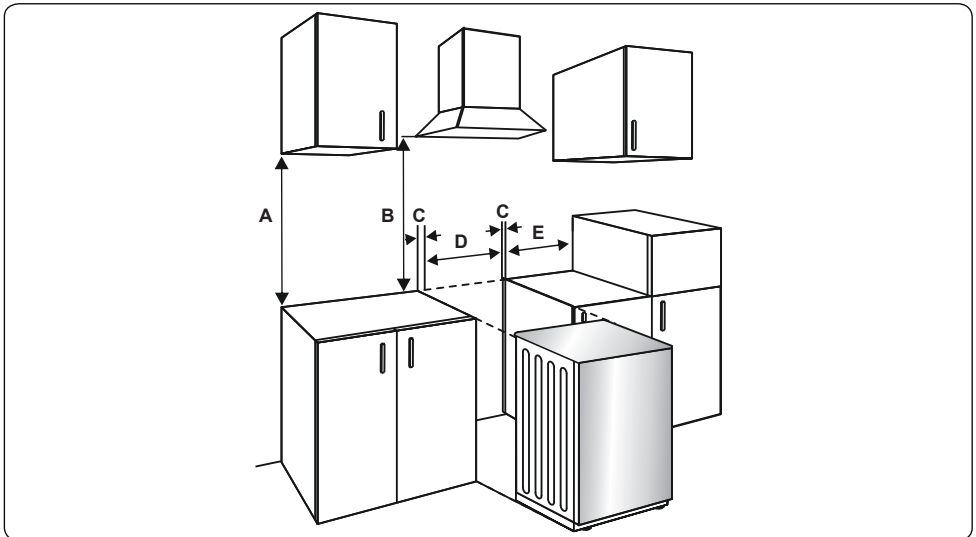

2.3 Gas Connection

Assembly of gas supply and leakage check

Connect the appliance in accordance with applicable local and international standards and regulations. First, check what type of gas is installed on the cooker. This information is available on a sticker on the back of the cooker. You can find the information related to appropriate gas types and appropriate gas injectors in the technical data table. Check that the feeding gas pressure matches the values on the technical data table, to be able to get the most efficient use and to ensure the minimum gas consumption. If the pressure of used gas is different than the values stated or is not stable in your area, it may

be necessary to assemble an available pressure regulator on the gas inlet. You should contact an authorised service centre to make these adjustments.

Points that must be checked during flexible hose assembly:

- If the gas connection is made by a flexible hose fixed onto the gas inlet of the hob, it must be fixed on by a pipe collar.
- Connect your appliance with a short and durable hose that is as close as possible to the gas source.
- The permitted maximum length of the hose is 1.5 m.

- The device should be connected in line with the relevant local gas standards.
- The hose must be kept clear of areas that may heat up to temperatures of more than 90°C.
- The hose must not be cracked, torn, bent or folded.
- Keep the hose clear of sharp corners and objects that could move.
- Before you assemble the connection, you must make sure the hose is not damaged. Use bubbly water or leakage fluids to perform the check. Do not use a naked flame to check for gas leakage.
- All metal items that are used during gas connection must be free from rust. Check the expiry date of any components used for connection.

Points that must be checked during fixed gas connection assembly

The method used to assemble a fixed gas connection (gas connection made by threads, e.g. a nut) varies according to the country you are in. The most common parts for your country will be supplied with your appliance. Any other parts required can be supplied as spare parts.

During connection, always keep the nut on the gas manifold fixed while rotating the counter-part. Use appropriately-sized spanners for a safe connection. For surfaces between different components always use the seals provided in the gas conversion kit.

The seals used during connection should also be approved to be used in gas connections. Do not use plumbing seals for gas connections.

Remember that this appliance is ready to be connected to the gas supply in the country for which it has been produced. The main country of destination is marked on the rear cover of the appliance. If you need to use it in another country, any of the connections in the figure below may be required. In such a case, contact local authorities to learn the correct gas connection.

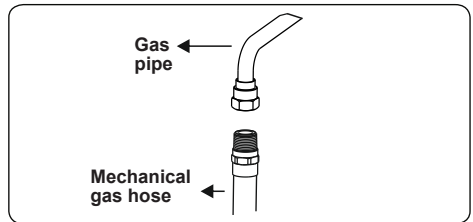
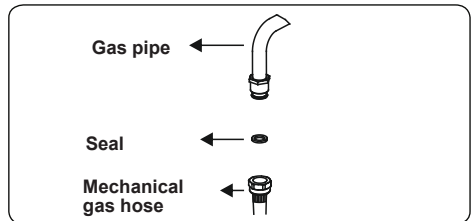
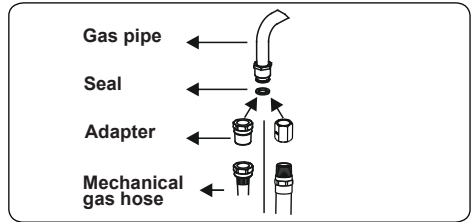
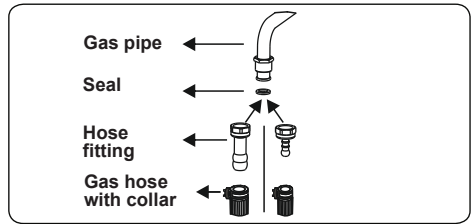

The Cooker must be installed and maintained by a suitably qualified gas registered technician in accordance with current safety legislation.

⚠ WARNING: Do not use a naked flame to check for gas leaks.

2.4 Gas Conversion (if available)

Your appliance is designed to be operated with LPG/NG gas. The gas burners can be adapted to different types of gas, by replacing the corresponding injectors and adjusting the minimum flame length suitable to the gas in use. For this purpose, the following steps should be performed.

Changing injectors
Hob burners

- Cut off the main gas supply and unplug the appliance from the mains electrical supply.
- Remove the burner caps and the adapters.
- Use a 7 mm spanner to unscrew the injectors.
- Replace the injector with the ones from the gas conversion kit, with the correct diameters for the type of gas that is going to be used, according to the gas injector table.

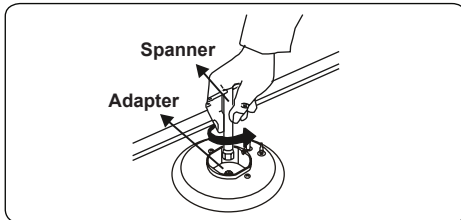
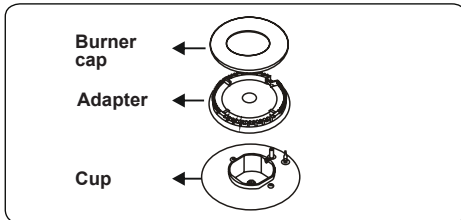

Adjusting the minimum flame position:

First of all, make sure that the appliance is unplugged from the mains electrical supply and that the gas feed is open. The minimum flame position is adjusted with a flat screw located on the valve. For valves with a flame failure safety device, the screw is located on the side of the valve spindle as shown in the figures. For valves without a flame failure safety device, the screw is located inside the valve spindle as shown in the figure. To make adjusting the flame position easier, we recommend that you remove the control panel (and the micro switch if your model has one) during the alteration. The bypass screw must be loosened for conversion from LPG to NG. For conversion from NG to LPG, the bypass screw must be tightened.

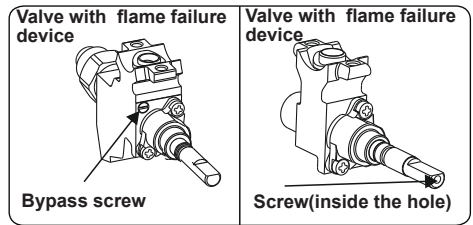

Determining the minimum flame position

To determine the minimum position, ignite the burners and leave them on in the minimum position. Remove the knobs because the screws are accessible only when the knobs are removed. With the help of a small screwdriver, fasten or loosen the bypass screw by around 90 degrees. When the flame has a length of at least 4mm, the gas is well distributed. Make sure that the flame does not die out when passing from the maximum position to the minimum position. Create an artificial wind with your hand towards the flame to see if the flames are stable.

Changing the gas inlet

For some countries, the gas inlet type can be different for NG/LPG gases. In this case, remove the current connection components and nuts (if any) and connect the new gas supply accordingly. In all conditions, all components used in gas connections should be approved by local and/or international authorities. In all gas connections, refer to the "Assembly of gas supply and leakage check" clause explained above.

2.5 Electrical Connection and Safety (if available)

⚠ WARNING: The electrical connection of this appliance should be carried out by an authorised service person or qualified electrician, according to the instructions in this guide and in compliance with the current local regulations.

⚠ WARNING: THE APPLIANCE MUST BE EARTHED.

- Before connecting the appliance to the power supply, the voltage rating of the appliance (stamped on the appliance identification plate) must be checked for correspondence to the available mains supply voltage, and the mains electric wiring should be capable of handling the appliance's power rating (also indicated on the identification plate).

- During installation, please ensure that isolated cables are used. An incorrect connection could damage your appliance. If the mains cable is damaged and needs to be replaced this should be done by a qualified personnel.
- Do not use adaptors, multiple sockets and/or extension leads.
- The supply cord should be kept away from hot parts of the appliance and must not be bent or compressed. Otherwise the cord may be damaged, causing a short circuit.
- If the appliance is not connected to the mains with a plug, a all-pole disconnector (with at least 3 mm contact spacing) must be used in order to meet the safety regulations.
- The appliance is designed for a power supply of 220-240 V~. If your supply is different, contact the authorized service personnel or qualified electrician.
- The power cable (H05VV-F) must be of sufficient length to be connected to the appliance.
- The fused switch must be easily accessible once the appliance has been installed.
- Ensure all connections are adequately tightened.
- Fix the supply cable in the cable clamp and then close the cover.
- The terminal box connection is placed on the terminal box.

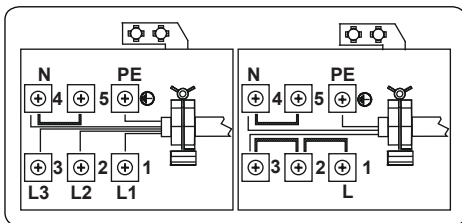

2.6 Anti-tilting kit

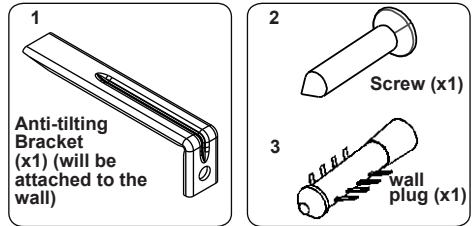

The document bag contains an anti-tilting kit. Loosely attach the anti-tilting bracket (1) to the wall using the screw (2) and wall plug (3), following the measurements shown in the figure and table below. Adjust the height of the anti-tilting bracket so that it lines up with the slot on the cooker and tighten the screw. Push the appliance towards the wall making sure that the anti-tilting bracket is inserted into the slot on the rear of the appliance.

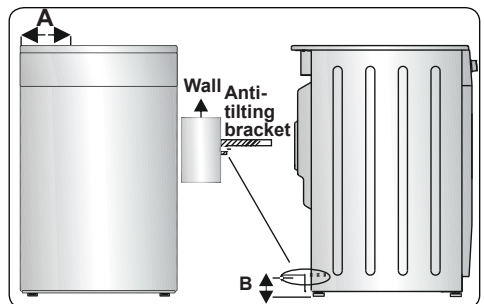

Product Dimensions (Width X Depth X Height) (Cm)	A (mm)	B (mm)
60x60x90 (Double Oven)	297.5	52
50x60x90 (Double Oven)	247.5	52
90x60x85	430	107
60x60x90	309.5	112
60x60x85	309.5	64
50x60x90	247.5	112
50x60x85	247.5	64
50x50x90	247.5	112
50x50x85	247.5	64

2.7 Adjusting the feet

Your product stands on four adjustable feet. For safe operation, it is important that your appliance is correctly balanced. Make

sure the appliance is level prior to cooking. To increase the height of the appliance, turn the feet anti-clockwise. To decrease the height of the appliance, turn the feet clockwise.

It is possible to raise the height of the appliance up to 30 mm by adjusting the feet. The appliance is heavy and we recommend that a minimum of 2 people lift it. Never drag the appliance.

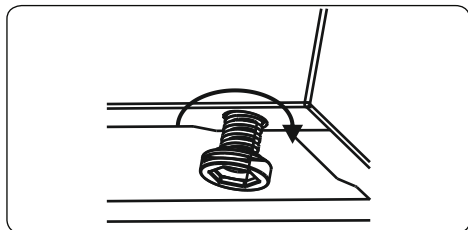

3. PRODUCT FEATURES



Important: Specifications for the product vary and the appearance of your appliance may differ from that shown in the figures below.

List of Components

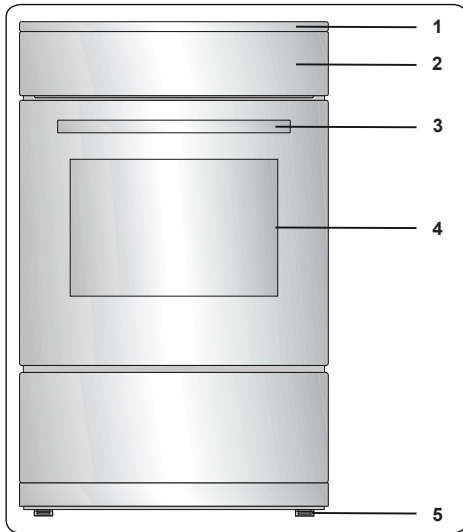

1. Cooktop
2. Control Panel
3. Oven Door Handle
4. Oven Door
5. Adjustable Feet

Control Panel

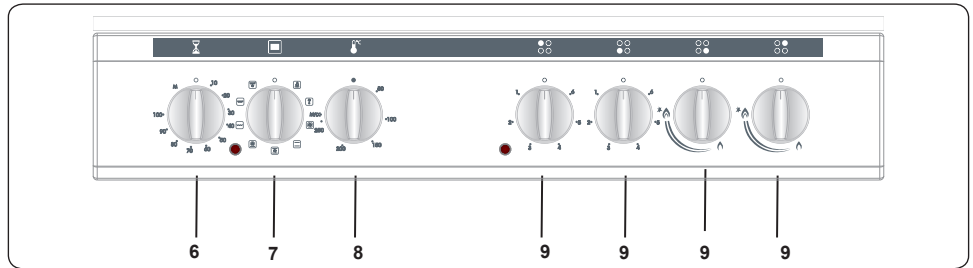

6. Timer
7. Oven Function Control Knob
8. Oven Thermostat Knob
9. Hob Control Knob

4. USE OF PRODUCT

4.1 Use of gas burners

Ignition of the burners

The position symbol above each control knob indicates the burner that the knob controls.

Manual Ignition of the Gas Burners

If your appliance is not equipped with an ignition aid, or in case there is a failure in the electric network, follow the procedures listed below.

For Hob Burners: Push in the knob of the burner you wish to ignite and keep it pressed while turning it anti-clockwise until the knob is in the 'maximum' position. Continue pressing the knob and hold a lit match, taper or other manual aid to the upper circumference of the burner. Move the ignition source away from the burner as soon as you see a stable flame.

Electrical ignition by control knob

Push in the knob of the burner you wish to ignite and keep it pressed while turning it anti-clockwise until the knob is in the 90 degrees position. The microswitch under the knob will create sparks through the spark plug for as long as the control knob is pressed. Press the knob until you see a stable flame on the burner.

Flame safety device

Hob burners

Hobs equipped with a flame failure device provide security in case of an accidentally extinguished flame. If such a case occurs, the device will block the burners gas lines and will avoid any accumulation of unburned gas. Wait 90 seconds before re-igniting an extinguished gas burner.

4.2 Hob Controls

Hob burner

The knob has 3 positions: off (0), maximum (big flame symbol) and minimum (small flame symbol). Ignite the burner with the knob in the 'maximum' position; you can then adjust the flame length between the 'maximum' and 'minimum' positions. Do not operate the burners when the knob is between the 'maximum' and 'off' positions.

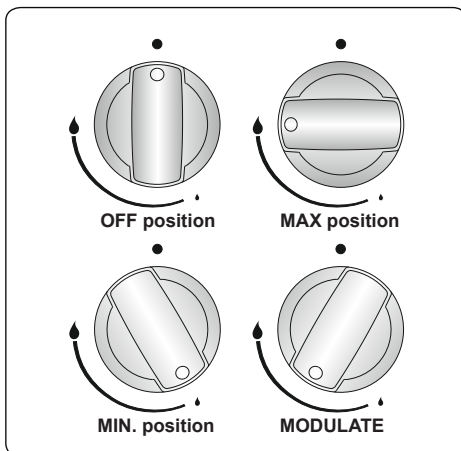

After ignition, visually check the flames. If you see a yellow tip, lifted or unstable flame, switch the gas flow off, then check the assembly of burner caps and crowns once they have cooled. Make sure there is no liquid in the burner caps. If the burner flames go out accidentally, switch the burners off, ventilate the kitchen with fresh air and wait at least 90 seconds before attempting re-ignition.

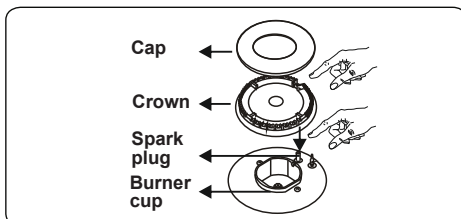

To switch the hob burners off, turn the hob burner knob clockwise to the '0' position or so that the marker on the hob burner knob points upwards.

Your hob has burners of different diameters. You will find that the most economical way of using gas is to choose the correct size gas burner for your cooking pan size and to bring the flame to the 'minimum' position once boiling point is reached. We recommend that you always cover your cooking pan to avoid heat loss.

To obtain maximum performance from the main burners, we suggest you use pots with the following flat bottom diameters. Using pots smaller than the minimum dimensions shown below will cause energy loss.

Rapid / Wok Burner	22-26 cm
Semi-rapid Burner	14-22 cm
Auxiliary Burner	12-18 cm

Make sure that the tips of the flames do not spread out from the outer circumference of the pan, as this may harm plastic accessories, such as handles.

Switch the main gas control valve off when the burners are not in use for prolonged periods of time.

WARNING:

- Only use flat-bottomed pans with thick bases.
- Make sure the bottom of the pan is dry before placing it on the burner.
- The temperature of accessible parts may become high while the appliance is operating. It is imperative that children and animals are kept well away from the burners during and after cooking.
- After use, the hob remains very hot for a prolonged period of time. Do not touch it and do not place any object on top of it.
- Never place knives, forks, spoons and lids on the hob as they will get hot and could cause serious burns.
- Do not allow pan handles or any other cooking utensils to project over the edge of the cooker top.

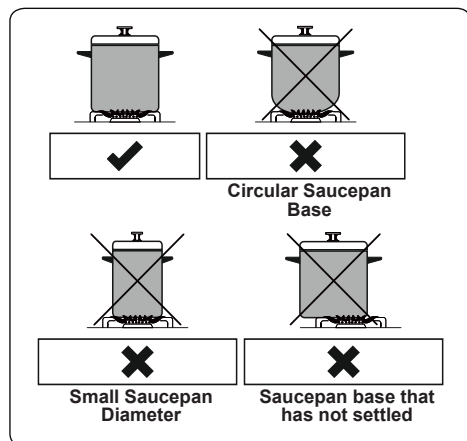

Hob Controls

Hotplate

The hotplate is controlled by a knob with 6 positions.

The hotplate can be operated by switching the control knob to one of these positions. Near each hob control knob, there is a small symbol that shows which hotplate is controlled by that knob. The on/off light on the control panel shows which hotplates are in use.

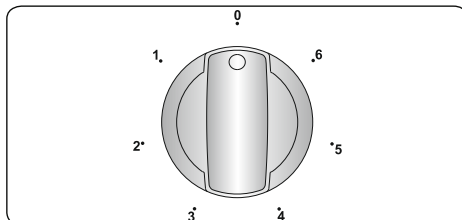

Knob Position	Function
0	Off position
1	To melt butter etc. and to warm small quantities of liquid
2	To warm bigger quantities of liquid. To prepare creams and sauces
3	To defrost food for cooking
4	To cook delicate meat and fish
5	To roast meat and steak
6	To boil big quantities of liquid or to fry

WARNING:

- When operating the hotplate for the first time, or after it has not been used for a prolonged period of time, it is necessary to eliminate any humidity which may have accumulated around the electrical elements of the plate. To do this, operate the hotplate on its lowest setting for about 20 minutes.
- Never operate a hotplate without pans on. Otherwise, form defects may occur on the cooktop.
- Only use flat-bottomed pans with thick bases.
- Make sure the bottom of the pan is dry before placing it on a hotplate.
- When a hotplate is in operation, make sure that the pan is centred correctly

on it.

- Never use a pan with a smaller or larger diameter than that of the hotplate as this will waste energy.

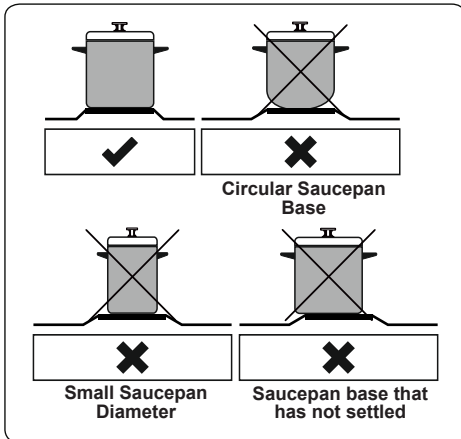

- If possible, always place lids on the pans to avoid heat loss.
- The temperature of accessible parts may become high while the appliance is operating. It is imperative to keep children and animals well away from the hob during use and until it has fully cooled after use.
- If you notice a crack on the cooktop, it must be immediately switched off and replaced by an authorized service personnel or technician.

4.3 Oven Controls

Oven function control knob

Turn the knob to the corresponding symbol of the desired cooking function. For the details of different functions see 'Oven Functions'.

Oven thermostat knob

After selecting a cooking function, turn this knob to set the desired temperature. The oven thermostat light will illuminate whenever the thermostat is in operation to heat up the oven or maintain the temperature.

Oven Functions

* The functions of your oven may be different due to the model of your product.

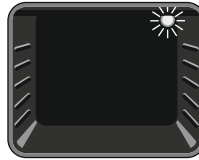

Oven Lamp: Only the oven light will switch on. It will remain on for the duration of the cooking function.

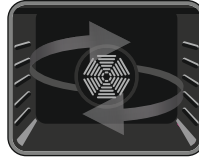

Defrost Function: The oven's warning lights will switch on and the fan will start to operate. To use the defrost function, place your frozen food in the oven on a shelf in the third slot from the bottom. It is recommended that you place an oven tray under the defrosting food to catch the water accumulated due to melting ice. This function will not cook or bake your food, it will only help to defrost it.

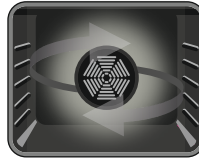

Turbo Function: The oven's thermostat and warning lights will switch on, and the ring heating element and fan will start operating. The turbo function evenly disperses the heat in the oven so all food on all racks will cook evenly. It is recommended that you preheat the oven for about 10 minutes.

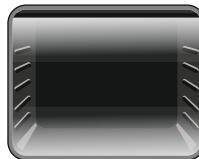

Static Cooking Function: The oven's thermostat and warning lights will switch on, and the lower and upper heating elements will start operating. The static cooking function emits heat, ensuring even cooking of food. This is ideal for making pastries, cakes, baked pasta, lasagne and pizza. Preheating the oven for 10 minutes is recommended and it is best to use only one shelf at a time in this function.



Fan Function: The oven's thermostat and warning lights will switch on, and the upper and lower heating elements and fan will start operating. This function is good for baking pastry. Cooking is carried out by the lower and upper heating elements within the oven and by the fan, which provides air circulation, giving a slightly grilled effect to the food. It

is recommended that you preheat the oven for about 10 minutes. The fan and lower heating function is ideal for baking food, such as pizza, evenly in a short period of time. The fan evenly disperses the heat of the oven, while the lower heating element bakes the food.

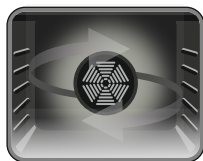

Pizza Function: The oven's thermostat and warning lights will switch on, and the ring, lower heating elements and fan will start operating. This function

is ideal for baking food, such as pizza, evenly in a short time. While the fan evenly disperses the heat of the oven, the lower heating element ensures baking of the food.

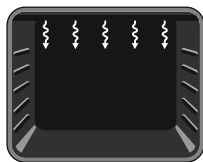

Grilling Function: The oven's thermostat and warning lights will switch on, and the grill heating element will start operating. This function is used for

grilling and toasting foods on the upper shelves of the oven. Lightly brush the wire grid with oil to stop food sticking and place food in the centre of the grid. Always place a tray beneath the food to catch any drips of oil or fat. It is recommended that you preheat the oven for about 10 minutes.

Warning: When grilling, the oven door must be closed and the oven temperature should be adjusted to 190°C.

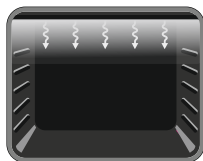

Faster Grilling Function: The oven's thermostat and warning lights will switch on, and the grill and upper heating elements will start

operating. This function is used for faster grilling and for grilling food with a larger surface area, such as meat. Use the upper shelves of the oven. Lightly brush the wire grid with oil to stop food sticking and place food in the centre of the grid. Always place a tray beneath the food to catch any drips of oil or fat. It is recommended that you preheat the oven for about 10 minutes.

Warning: When grilling, the oven door must be closed and the oven temperature should be adjusted to 190°C.

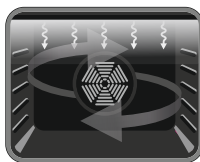

Double Grill and Fan Function: The oven's thermostat and warning lights will switch on, and the grill, upper heating elements and fan will

start operating. This function is used for faster grilling of thicker food and for grilling of food with a larger surface area. Both the upper heating elements and grill will be energised along with the fan to ensure even cooking. Use the upper shelves of the oven. Lightly brush the wire grid with oil to stop food sticking and place food in the centre of the grid. Always place a tray beneath the food to catch any drips of oil or fat. It is recommended that you preheat the oven for about 10 minutes.

Warning: When grilling, the oven door must be closed and the oven temperature should be adjusted to 190°C.

4.4 Use of the Mechanical Timer

Function Description	
M	Manual operation
0.....100	Operating by adjusting the timer

Manual operation

When you set the timer button to the "M" position, you will be able to continuously run your oven. When you set the timer button to the "0" position, the oven will not operate.

Operating by adjusting the timer

Set the desired cooking time by turning the timer knob to between 0 and 100 minutes. When the timer reaches zero, the oven will automatically switch off and an audible warning will sound.

4.5 Accessories

The Deep Tray

The deep tray is best used for cooking stews.

Put the tray into any rack and push it to the end to make sure it is placed correctly.

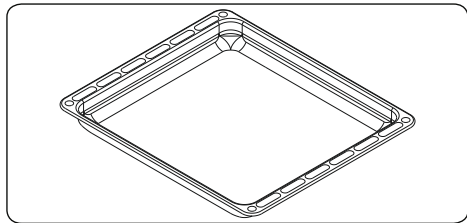

The Wire Grid

The wire grid is best used for grilling or for processing food in oven-friendly containers.

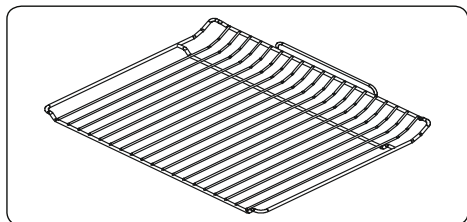

WARNING

Place the grid to any corresponding rack in the oven cavity correctly and push it to the end.

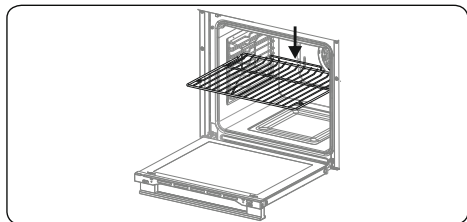

5. CLEANING AND MAINTENANCE

5.1 Cleaning

 **WARNING:** Switch off the appliance and allow it to cool before cleaning is to be carried out.

General Instructions

- Check whether the cleaning materials are appropriate and recommended by the manufacturer before use on your appliance.
- Use cream cleaners or liquid cleaners which do not contain particles. Do not use caustic (corrosive) creams, abrasive

cleaning powders, rough wire wool or hard tools as they may damage the cooker surfaces.

 Do not use cleaners that contain particles, as they may scratch the glass, enamelled and/or painted parts of your appliance.

- Should any liquids overflow, clean them immediately to avoid parts becoming damaged.

 Do not use steam cleaners for cleaning any part of the appliance.

Cleaning the Inside of the Oven

- The inside of enamelled ovens are best cleaned while the oven is warm.
- Wipe the oven with a soft cloth soaked in soapy water after each use. Then, wipe the oven over again with a wet cloth and then dry it.
- You may need to use a liquid cleaning material occasionally to completely clean the oven.

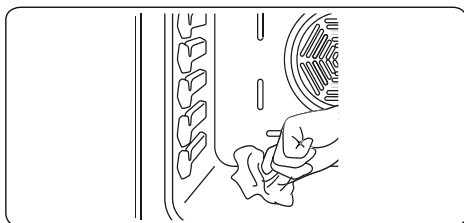

Cleaning the Gas Hob

- Clean the gas hob on a regular basis.
 - Take off the pan supports, caps and crowns of the hob burners.
 - Wipe the hob surface with a soft cloth soaked in soapy water. Then, wipe the hob surface over again with a wet cloth and dry it.
 - Wash and rinse the hob-burner caps. Do not leave them wet. Dry them immediately with a dry cloth.
 - Make sure you re-assemble all parts correctly after cleaning.
 - The surfaces of the pan supports may become scratched over time due to use. This is not a production fault.
-  Do not use a metal sponge for cleaning any part of the hob.

- ⓘ Make sure no water gets into the burners as this may block the injectors.

Cleaning the Hotplate Heater (if available)

- Clean the hotplate heater on a regular basis.
- Wipe the hotplate with a soft cloth soaked in only water. Then, run the hotplate for a short time to dry it completely.

Cleaning the Glass Parts

- Clean the glass parts of your appliance on a regular basis.
- Use a glass cleaner to clean the inside and outside of the glass parts. Then, rinse and dry them thoroughly with a dry cloth.

Cleaning the Enamelled Parts

- Clean the enamelled parts of your appliance on a regular basis.
- Wipe the enamelled parts with a soft cloth soaked in soapy water. Then, wipe them over again with a wet cloth and dry them.

- ⓘ Do not clean the enamelled parts while they are still hot from cooking.

- ⓘ Do not leave vinegar, coffee, milk, salt, water, lemon or tomato juice on the enamel for a long time.

Cleaning the Stainless Steel Parts (if available)

- Clean the stainless steel parts of your appliance on a regular basis.
- Wipe the stainless steel parts with a soft cloth soaked in only water. Then, dry them thoroughly with a dry cloth.

- ⓘ Do not clean the stainless steel parts while they are still hot from cooking.

- ⓘ Do not leave vinegar, coffee, milk, salt, water, lemon or tomato juice on the stainless steel for a long time.

Removal of the Inner Glass

You must remove the oven door glass before cleaning, as shown below.

1. Push the glass in the direction of **B** and release from the location bracket (**x**). Pull the glass out in the direction of **A**.

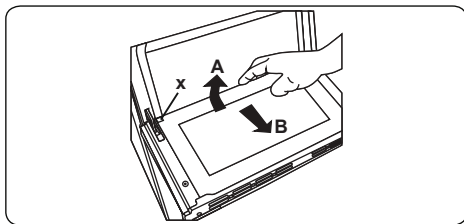

To replace the inner glass:

1. Push the glass towards and under the location bracket (**y**), in the direction of **B**.

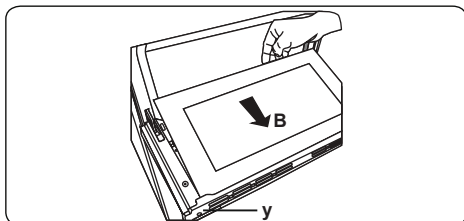

3. Place the glass under the location bracket (**x**) in the direction of **C**.

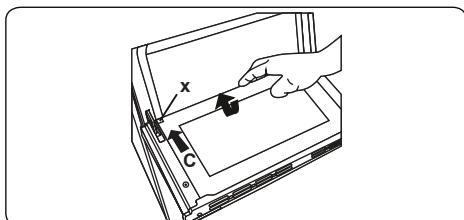

- ⓘ If the oven door is a triple glass oven door, the third glass layer can be removed the same way as the second glass layer.

Removal of the Oven Door

Before cleaning the oven door glass, you must remove the oven door, as shown below.

1. Open the oven door.

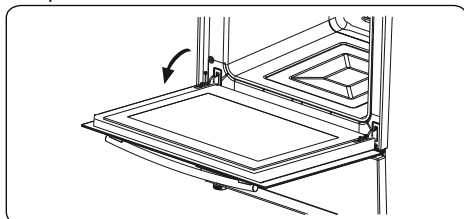

2. Open the locking catch (**a**) (with the aid of a screwdriver) up to the end position.

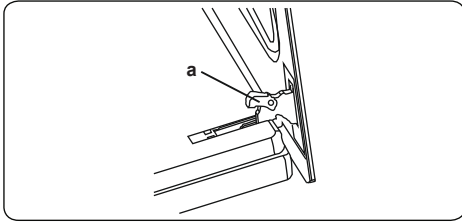

3. Close the door until it almost reaches the fully closed position and remove the door by pulling it towards you.

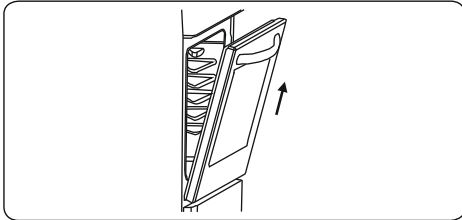

5.2 Maintenance

! **WARNING:** The maintenance of this appliance should be carried out by an authorised service person or qualified technician only.

Changing the Oven Lamp

! **WARNING:** Switch off the appliance and allow it to cool before cleaning your appliance.

- Remove the glass lens, then remove the bulb.
- Insert the new bulb (resistant to 300 °C) to replace the bulb that you removed (230 V, 15-25 Watt, Type E14).
- Replace the glass lens, and your oven is ready for use.

⚠ The lamp is designed specifically for use in household cooking appliances. It is not suitable for household room illumination.

5.3 Maintenance

! **WARNING:** The maintenance of this appliance should be carried out by an authorised service person or qualified technician only.

Other Controls

- Periodically check the gas connection pipe. If a defect is found, contact an authorised service provider to have it changed.
- We recommend the gas connection components are changed annually. If a defect is found while operating the control knobs of the appliance, contact an authorised service provider.

6. TROUBLESHOOTING&TRANSPORT

6.1 Troubleshooting



If you still have a problem with your appliance after checking these basic troubleshooting steps, please contact an authorised service person or qualified technician.

Problem	Possible Cause	Solution
Hob burners do not work.	The burners may be in the 'off' position. Supply gas pressure may not be correct. Power (if the appliance has an electric connection) is switched off.	Check the position of the control knob. Check the gas supply and gas pressure. Check whether there is power supplied. Also check that other kitchen appliances are working.
Hob burners do not light.	Burner cap and crown are not assembled correctly. Supply gas pressure may not be correct. LPG cylinder (if applicable) may be depleted. Power (if the appliance has an electric connection) is switched off.	Ensure the burner parts have been placed correctly. Check the gas supply and gas pressure. LPG cylinder may need replacing. Check whether power is being supplied. Also, check that other kitchen appliances are working.
Flame colour is orange/yellow.	Burner cap and crown are not assembled correctly. Different gas compositions.	Ensure the burner parts have been placed correctly. Due to the design of the burner, the flame can appear to be orange/yellow in certain areas of the burner. If you operate the appliance with natural gas, city natural gas may have different compositions. Do not operate the appliance for a couple of hours.
Burner is not igniting or only partially lighting.	Burner parts may not be clean or dry.	Ensure that parts of the appliance are dry and clean.
Burner sounds noisy.	-	This is normal. The noise may reduce as they heat up.
Noise	-	It is normal for some metal parts on the cooker to produce noise when in use.
The hob or cooking zones cannot be switched on.	There is no power supply.	Check the household fuse for the appliance. Check whether there is a power cut by trying other electronic appliances.
The hob produces an odour during the first cooking sessions.	New appliance.	Heat a saucepan full of water on each cooking zone for 30 minutes.
Oven does not switch on.	Power is switched off.	Check whether there is power supplied. Also, check that other kitchen appliances are working.
No heat or oven does not warm up.	Oven temperature control is incorrectly set. Oven door has been left open.	Check the oven temperature control knob is set correctly.

Cooking is uneven within the oven.	Oven shelves are incorrectly positioned.	<p>Check that the recommended temperatures and shelf positions are being used.</p> <p>Do not frequently open the door unless you are cooking things that need to be turned. If you open the door often, the interior temperature will be lower and this may affect the results of your cooking.</p>
Oven light (if available) does not operate.	<p>Lamp has failed.</p> <p>Electrical supply is disconnected or switched off.</p>	<p>Replace lamp according to the instructions.</p> <p>Make sure the electrical supply is switched on at the wall socket outlet.</p>
The oven fan (if available) is noisy.	Oven shelves are vibrating.	<p>Check that the oven is level.</p> <p>Check that the shelves and any bake ware are not vibrating or in contact with the oven back panel.</p>

6.2 Transport

If you need to transport the product, use the original product packaging and carry it using its original case. Follow the transport signs on the packaging. Tape all independent parts to the product to prevent damaging the product during transport.

If you do not have the original packaging, prepare a carriage box so that the appliance, especially the external surfaces of the product, is protected against external threats.

7. TECHNICAL SPECIFICATIONS

7.1 Injector Table(FXC 522M)

G30 28-30mbar 4.8 kW 345 g/h II2H3B/P BG Clase: 1	NG G20 20 mbar	LPG G30 28-30 mbar
LARGE BURNER		
DIA. of INJECTOR (1/100mm)	115	85
NOMINAL RATING (KW)	2,9	3
CONSUMPTION	276 l/h	218,1 g/h
MEDIUM BURNER		
DIA. of INJECTOR (1/100mm)	97	65
NOMINAL RATING (KW)	1,75	1,75
CONSUMPTION	166,7 l/h	127,2 g/h

7.2 Injector Table(FXC 622M)

7.3 G30 28-30mbar 4.8 kW 345 g/h II2H3B/P BG Class: 1	7.4 NG G20 20 mbar	7.5 LPG G30 28-30 mbar
7.6 LARGE BURNER		
7.7 DIA. of INJECTOR (1/100mm)	7.8 115	7.9 85
7.10 NOMINAL RATING (KW)	7.11 2,75	7.12 3
7.13 CONSUMPTION	7.14 261,9 l/h	7.15 218,1 g/h
7.16 MEDIUM BURNER		
7.17 DIA. of INJECTOR (1/100mm)	7.18 97	7.19 65
7.20 NOMINAL RATING (KW)	7.21 1,75	7.22 1,75
7.23 CONSUMPTION	7.24 166,7 l/h	7.25 127,2 g/h

52278692

